

# WP225

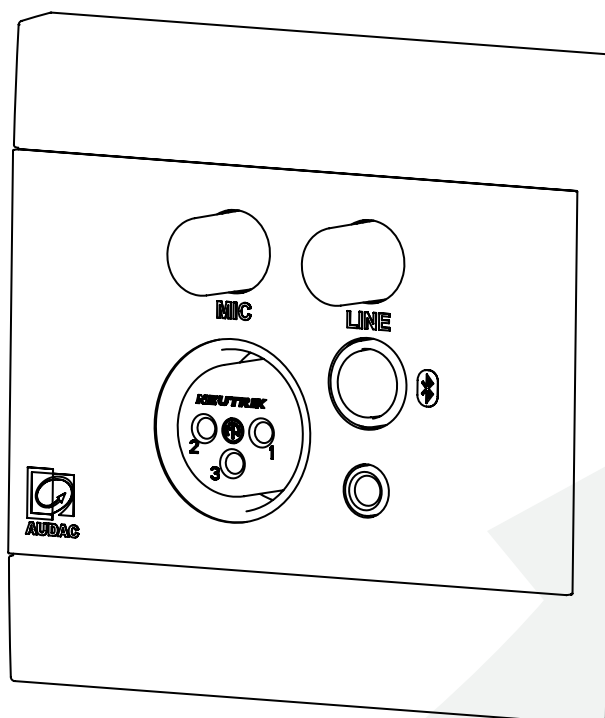

#### **ADDITIONAL INFORMATION**

This manual is put together with much care, and is as complete as could be on the publication date. However, updates on the specifications, functionality or software may have occurred since publication. To obtain the latest version of both manual and software, please visit the Audac website @ [www.audac.eu](http://www.audac.eu).



# Table of contents



<b>Introduction</b>	<b>05</b>
Universal wall panel - Microphone, line & Bluetooth receiver .....	05
<b>Precautions</b>	<b>06</b>
<b>Chapter 1</b>	<b>07</b>
Overview front panel .....	07
Front panel description .....	07
Overview rear panel .....	08
Rear panel description .....	08
<b>Chapter 2</b>	<b>09</b>
Quick start guide .....	09
<b>Chapter 3</b>	<b>010</b>
Connections .....	010
<b>Technical specifications</b>	<b>011</b>



## Universal wall panel - Microphone, line & Bluetooth receiver

The WP225 is a remote wall mixer that can be used in combination with various AUDAC devices. It converts the signal coming from a stereo line-level audio source (such as a tuner, mobile devices, ... ) or balanced microphone to the level corresponding to the differential signal input making it possible to transfer high-quality audio over long distances between the wall panel and the loudspeaker, by just using inexpensive twisted-pair CAT5e or better cabling. On the front side of the wall panel, there is a 3.5 mm jack stereo line input connection available together with a balanced XLR microphone input, both provided with their own knob which allows the signals to be mixed together.

It also features a Bluetooth receiver and pair button with a handy LED status to check if its in pairing mode or already connected to a device. Bluetooth pair name can be customized as desired. The Bluetooth receiver works with iPhones, iPads, iOS & Android smartphones, tablets, PC, Laptops, Desktops, etc...

The WP225 is available in 2 colours and is compatible with most standard EU style in-wall boxes for solid and hollow walls. With the Elegant ABS front panel with glass, it will blend into any environment.

## READ FOLLOWING INSTRUCTIONS FOR YOUR OWN SAFETY

ALWAYS KEEP THESE INSTRUCTIONS. NEVER THROW THEM AWAY

ALWAYS HANDLE THIS UNIT WITH CARE

HEED ALL WARNINGS

FOLLOW ALL INSTRUCTIONS

NEVER EXPOSE THIS EQUIPMENT TO RAIN, MOISTURE, ANY DRIPPING OR SPLASHING LIQUID. AND NEVER PLACE AN OBJECT FILLED WITH LIQUID ON TOP OF THIS DEVICE

NO NAKED FLAME SOURCES, SUCH AS LIGHTED CANDLES, SHOULD BE PLACED ON THE APPARATUS

DO NOT PLACE THIS UNIT IN AN ENCLOSED ENVIRONMENT SUCH AS A BOOKSHELF OR CLOSET. ENSURE THERE IS ADEQUATE VENTILATION TO COOL THE UNIT. DO NOT BLOCK THE VENTILATION OPENINGS.

DO NOT STICK ANY OBJECTS THROUGH THE VENTILATION OPENINGS.

DO NOT INSTALL THIS UNIT NEAR ANY HEAT SOURCES SUCH AS RADIATORS OR OTHER APPARATUS THAT PRODUCE HEAT

DO NOT PLACE THIS UNIT IN ENVIRONMENTS WHICH CONTAIN HIGH LEVELS OF DUST, HEAT, MOISTURE OR VIBRATION

THIS UNIT IS DEVELOPED FOR INDOOR USE ONLY. DO NOT USE IT OUTDOORS

PLACE THE UNIT ON A STABLE BASE OR MOUNT IT IN A STABLE RACK

ONLY USE ATTACHMENTS & ACCESSORIES SPECIFIED BY THE MANUFACTURER

UNPLUG THIS APPARATUS DURING LIGHTNING STORMS OR WHEN UNUSED FOR LONG PERIODS OF TIME

ONLY CONNECT THIS UNIT TO A MAINS SOCKET OUTLET WITH PROTECTIVE EARTHING CONNECTION

THE MAINS PLUG OR APPLIANCE COUPLER IS USED AS THE DISCONNECT DEVICE, SO THE DISCONNECT DEVICE SHALL BE READILY OPERABLE

USE THE APPARATUS ONLY IN MODERATE CLIMATES



### CAUTION - SERVICING

This product contains no user serviceable parts. Refer all servicing to qualified service personnel. Do not perform any servicing (unless you are qualified to)



### EC DECLARATION OF CONFORMITY

This product conforms to all the essential requirements and further relevant specifications described in following directives: 2014/30/EU (EMC), 2014/35/EU (LVD) & 2014/53/EU (RED).



### WASTE ELECTRICAL AND ELECTRONIC EQUIPMENT (WEEE)

The WEEE marking indicates that this product should not be disposed with regular household waste at the end of its life cycle. This regulation is created to prevent any possible harm to the environment or human health.

This product is developed and manufactured with high quality materials and components which can be recycled and/or reused. Please dispose this product at your local collection point or recycling centre for electrical and electronic waste. This will make sure that it will be recycled in an environmentally friendly manner, and will help to protect the environment in which we all live.

## Overview front panel

On the front of the wall panel you will find a Bluetooth pair button with a convenient LED indicator to check if it is in pairing mode or already connected to a device. The Bluetooth pairing name can be customized as desired. There is also an unbalanced 3.5 mm jack stereo line input connection available together with a balanced XLR microphone input, both provided with their own knob which allows the signals to be mixed together.

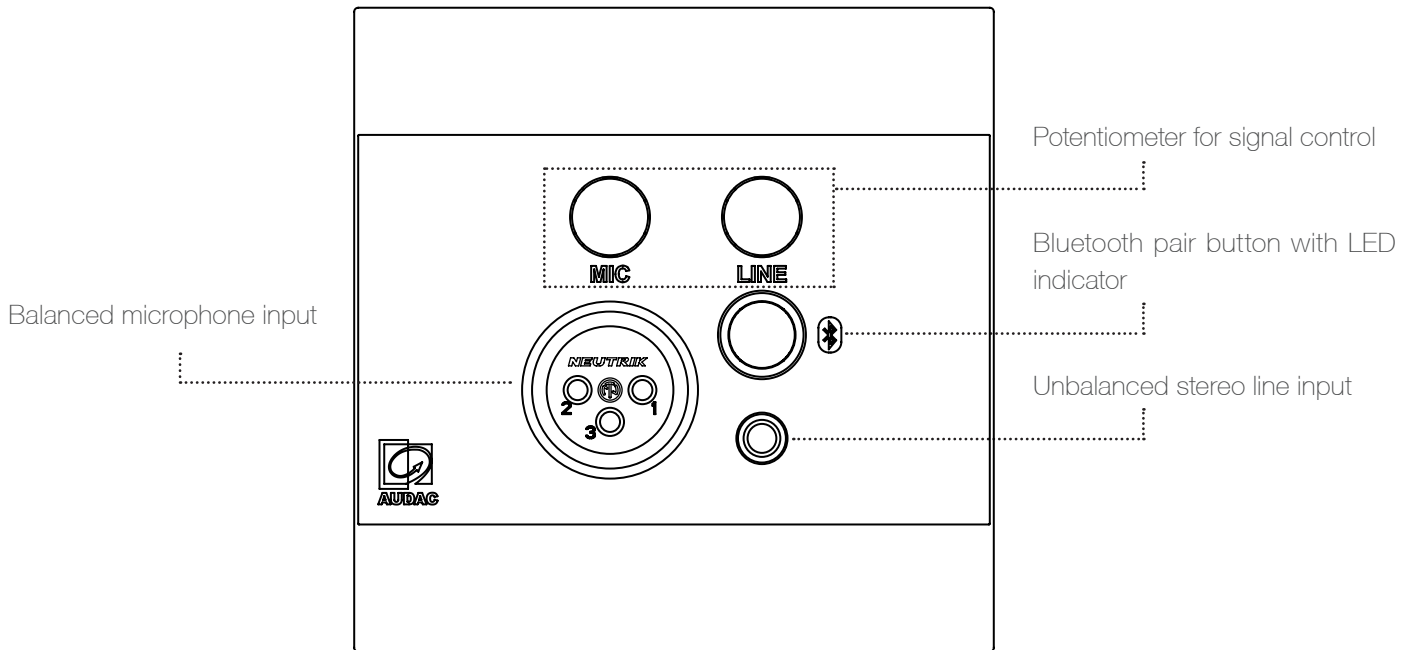

## Front panel description

### Bluetooth pairing button with LED

Pressing the bluetooth button will put the WP225 into pairing mode. This can be recognized by the blinking of the blue LED. If the wall panel is connected to a device the LED will be constantly lit. If the button is pushed again, the connection will be disconnected and the WP225 will go back into pairing mode.

### Balanced microphone input

A balanced microphone can be connected to this XLR input connector. For powering condenser microphones, Phantom power can be enabled.

### Unbalanced line input

An unbalanced stereo audio source can be connected to this 3.5mm jack stereo line input.

### Potentiometers for signal control

The individual signal levels for the line and microphone inputs can be adjusted with these potentiometers. This feature allows for the signals to be mixed together.

## Overview rear panel

The rear of the WP225 contains an 8-pin Terminal Block connector, which is used to connect the wall panel to the twisted pair cabling. Below the 8-pin connector is a 6-pin connector. This input connector is a duplicate of the line and mic input but for permanent connections. Below of the 6-pin connector are some DIP switches. These switches allow certain functions to be turned on or off, depending on the situation the WP is in.

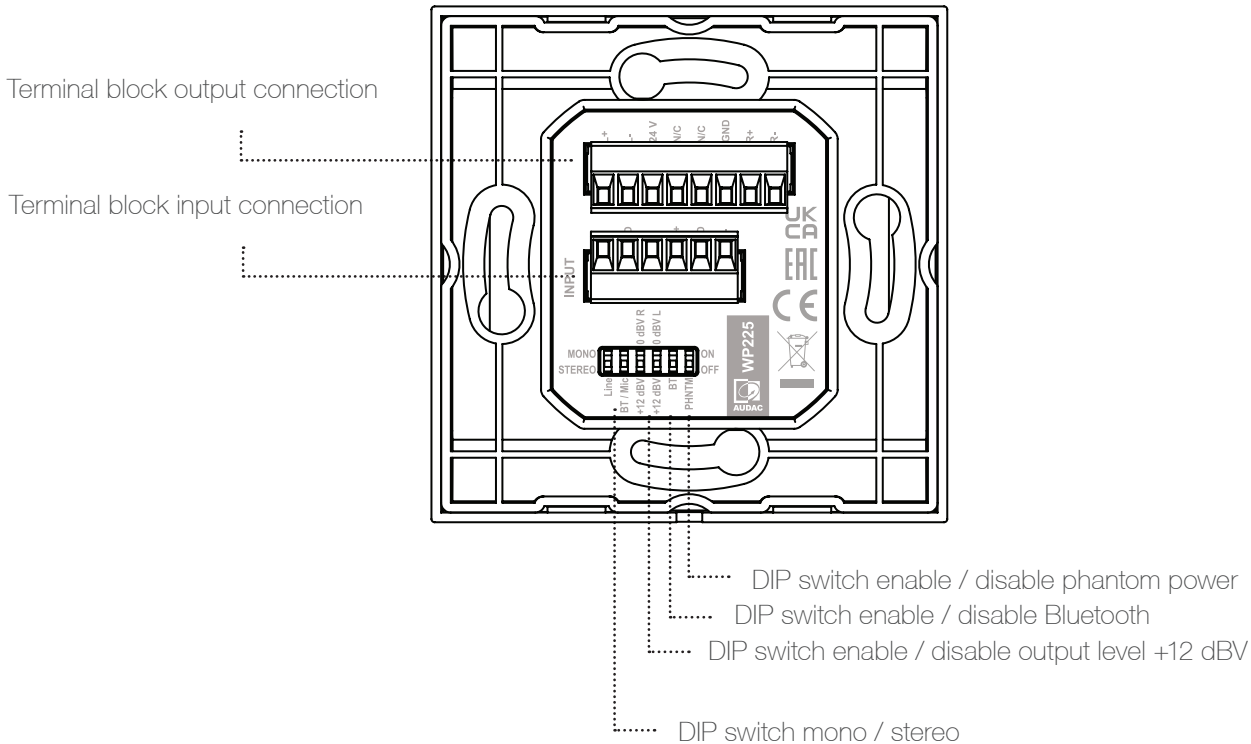

## Rear panel description

### 8-pin terminal block (3.81 mm pitch) output connection

The rear of the WP225 contains an 8-pin Euro-Terminal Block connector, where the wall panel must be connected to twisted pair cabling. For more information on how to make the connections can be found under "Connecting" in Chapter 3 of this manual.

### 6-pin terminal block (3.81 mm pitch) input connection

The 6-pin Euro-Terminal block is an input connector. This is a duplicate of the mic and line inputs but for a permanent connection.

### DIP switches

DIP switch enable / disable phantom power: The phantom power for the microphone input can be enabled or disabled.

DIP switch enable / disable Bluetooth: This switch enables or disables the Bluetooth function.

DIP switch enable / disable output level +12 dBV: When the option of +12 dBV is enabled, the wall panel is compatible with remote input devices. When it is disabled, the wall panel is compatible with standard line inputs (0 dBV)

DIP switch mono / stereo: This switch allows the operation mode to be switched between mono and stereo mode for the Line or Mic signal. When the wall panel is used in mono mode, the input signal applied to both the left and right input signal will be mixed. This mixed signal will be applied to both the left and right outputs.



## Quick start guide

This chapter guides you through the process for a basic setup where a WP225 should be connected to a system with wired network. Install your wall panel on the desired location by means of the optional available WB45S/FS (for solid walls) or WB45S/FG (for hollow walls) installation boxes. Provide a twisted pair cable (CAT5E or better) from the receiving device to the wall panel.

Connect the 8-pin terminal block to a receiving device with a twisted pair cable. After all those connections are made, just plug-in the connectors of the twisted pair cable, plug in the mains power on the loudspeaker side and your system is ready for operation.

You can connect your line, microphone and Bluetooth audio sources to the wall-panel, and your sounds should be audible through the system.

## Connecting a remote input to a line input connection

WP2xx series

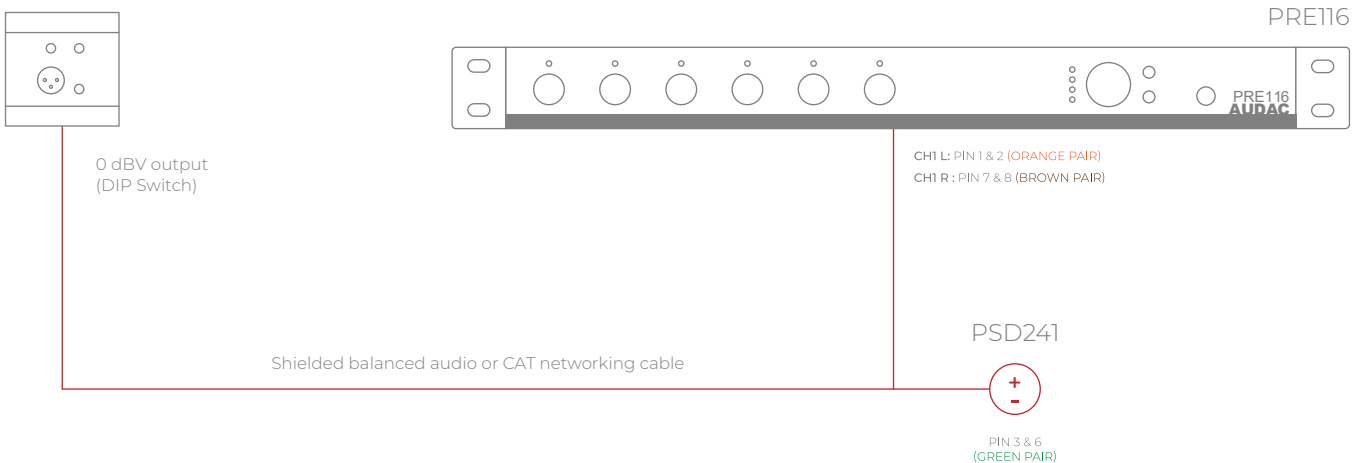

## Connections

### CONNECTION STANDARDS

The in- and output connections for AUDAC audio equipment are performed according to international wiring standards for professional audio equipment

#### 3.5 mm jack:

For unbalanced line input connections

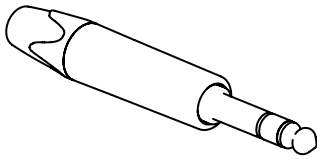

**Tip:** Left  
**Ring:** Right  
**Sleeve:** Ground

#### XLR

For balanced line input connections

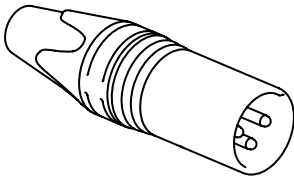

**PIN 1:** Ground  
**PIN 2:** Signal +  
**PIN 3:** Signal -

#### Wall panel rear audio input connection:

6-pin terminal block connector (3.5mm pitch)

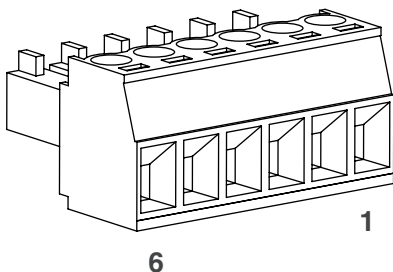

**PIN 1:** Mic -  
**PIN 2:** GND  
**PIN 3:** Mic +  
**PIN 4:** Line L  
**PIN 5:** GND  
**PIN 6:** Line R

#### Terminal block (Audio, +24V DC)

For connection to Wall Panels

The 8-pin Euro-Terminal Block on the rear side of the WP225 should be connected to twisted pair cabling. The maximum cable distance between the input unit and the speaker system can reach up to 100 meter. To ensure a proper working of the system, all 8 conductors of the twisted pair cable have to be connected according to the table below.

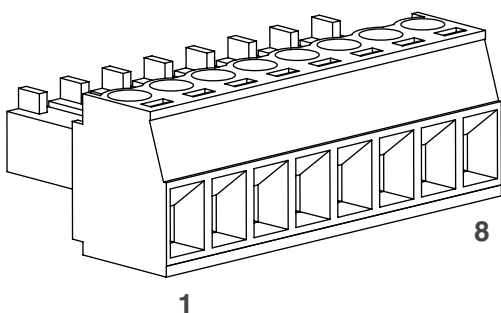

<b>Pin 1</b>	White-Orange	Left +
<b>Pin 2</b>	Orange	Left -
<b>Pin 3</b>	White-Green	+24V DC
<b>Pin 4</b>	Blue	Not connected
<b>Pin 5</b>	White-Blue	Not connected
<b>Pin 6</b>	Green	GND
<b>Pin 7</b>	White-Brown	Right +
<b>Pin 8</b>	Brown	Right -

# Technical specifications



Inputs	Type	<b>Integrated Bluetooth receiver</b>
	Version	BT5.0
	Frequency band	2.4 GHz
	Type	<b>Stereo unbalanced line</b>
	Connector	Front: 3.5mm jack
		Rear: 6-pin terminal block 3.81mm
	Impedance	7,7 kOhm
	Sensitivity	-6 dBV / +26 dBV
	THD+N	<0,2%
	Signal / Noise	72 dB
	Type	<b>Balanced microphone</b>
	Connector	Front: female XLR
		Rear: 6-pin terminal block 3.81mm
	Impedance	1 kOhm
	Sensitivity	-45 dBV / -10 dBV
	THD+N	<0,02%
	Signal / Noise	> 75 dB
Output	Type	<b>Stereo</b>
	Connector	8-pin terminal block 3.81mm
	Output level	Switch between 0dBV and 12 dBV
Power consumption		< 1,5W
Power supply		17V - 24V
Phantom power		24V DC (depending on input voltage)
Noisefloor		-76.5 dBV
Dimensions		80 x 80 x 52.7 mm (W x H x D)
Built-In depth		47 mm
Colours		Black (RAL9005)
		White (RAL9003)
Front finish		ABS with glass
Accessories	Solid wall	WB45S/FS
	Hollow wall	WB45S/FG
Compatible devices		ARES5A
		MTX48 / MTX88
		AMP523
		APG20



---

Discover more on [audac.eu](http://audac.eu)