

PROJECTOR LIFT MODEL SI-100 INSTALLATION MANUAL

Thank you for purchasing the new SI-100 Projector Lift.

The SI-100 is supplied with a set of components and accessories that make it suitable for installation for the majority of standard AV applications, but note must be made of the restrictions that apply to the weight capability of this unit and not exceeded.

Projector lift SI-100 **MUST BE INSTALLED BY SPECIALIZED PERSONNEL ONLY.**

Before installing the projector lift, please read the following instructions carefully:

- **The projector lift must be used INDOORS ONLY.**
- **IT IS FORBIDDEN TO STAY UNDER THE LIFT.**
- **NEVER CONNECT MORE THAN ONE LIFT MOTOR TO THE SAME SWITCHER. Use the supplied switcher only.**
- **IN CASE OF MAINTENANCE, UNPLUG THE POWER SUPPLY.**
- **In case the lift is controlled via relais, take care that the control system is programmed so there is no tension on the relais for at least 1 sec. during switching between rolling up and rolling down operations and viceversa.**
- **Please confirm that your projected image width will fit your screen from your proposed mounting location prior to installation.**
- **Incorrect use of the lift, including exceeding the maximum lifting weight, would be dangerous and invalidate the warranty.**
- **The manufacturer does not take responsibility for any damage to property or personal injury, if the lift is used outside of recommended specifications.**
- **This product uses a 230V AC Motor. DO NOT attempt to service the motor.**
- **Incorrect servicing could lead to risk of electric shock.**
- **For any repairing, please contact directly the dealer you purchased the unit from.**
- **Check at least once a year that the screws of the steel cables are well tightened and that the steel cables are in good conditions. In case they have signs of usage or damages, replace them promptly with the original ones supplied by the manufacturer.**

SUPPLIED EQUIPMENT LIST

When you open the packaging, please CHECK that it contains ALL the components below. In case one or more components are missed, please refer to the dealer you purchased the product from.

- A) 1 MECHANIC PROJECTOR LIFT SUPPLIED WITH A CABLE CHAIN AND MOTOR WITH A 3 METER CABLE WITH FOUR ELECTRIC WIRES (UP, DOWN, NEUTRAL AND EARTH)
- B) 4 "L" FORM ALUMINIUM BRACKETS FOR CEILING MOUNTING
- C) ON/OFF SWITCH UNIT
- D) INSTRUCTIONS FOR ELECTRICAL CONNECTIONS BETWEEN MOTOR AND SWITCHER
- E) 4 THREADED BARS M6 L. 25 CM
- F) 8 HEXAGONAL SCREWS 6x14 MM.
- G) 12 NUTS M6 FOR MOUNTING THE THREADED BARS TO THE SLIDING BRACKETS
- H) 4 SLIDING BRACKETS TO SUPPORT THE FALSE CEILING PLATE
- I) 4 HEX HEAD SCREWS 6X10 MM. FOR FIXING THE SLIDING BRACKETS TO THE LIFT FRAME
- J) 4 BLIND SCREWS M6 AND 4 BUSHES M6 FOR FIXING THE FALSE CEILING PLATE TO THE THREADED BARS

INSTALLATION INSTRUCTIONS

Use the hexagonal screws listed as "F" in the equipment list, to mount the "L" brackets to the profile of the lift, as shown in PICTURES 1A, 1B and 1C below:

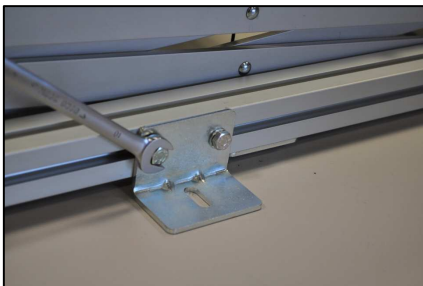

PICTURE 1A



PICTURE 1B



PICTURE 1C

Mount the lift to the ceiling using the suitable bolts/screws (NOT SUPPLIED) and verify that the projector lift is perfectly horizontal using a spirit level. Use shims to level the lift, if required, between the brackets and ceiling. Installing the lift perfectly level is **IMPORTANT** and ensures silent movement of the lift without any shaking, jolting or friction that would compromise the alignment between projector and projection screen. Once you have mounted the lift, position the projector either on or under the grill using the screws indicated in the instruction manual of your projector, as shown on PICTURES 2A, 2B and 2C. **Please take care that the projector's centre of gravity is located in the middle of the grille.**



PICTURE 2A



PICTURE 2B



PICTURE 2C

Connect the projector lift to the mains as explained on the attached instructions for electrical connections (**PICTURE 2D**).

The next step is to set the "UPPER END STOP POSITION" (CLOSED lift) and the "LOWER END STOP POSITION" (OPEN lift).

If the projector lift has been positioned inside a false ceiling void, please be aware that to allow full closure the threaded bars that support the trim kit must be no longer than 25cm in length in order to use the equipment listed under (E) on page 1. The "LOWER END STOP POSITION" has to be regulated so that the image is correctly projected onto the screen.

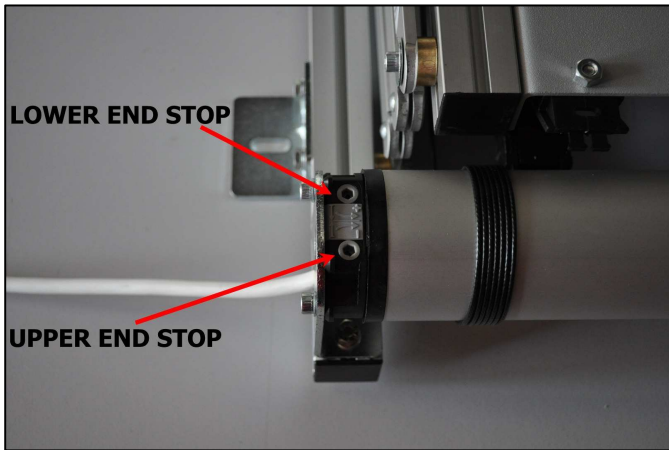

In order to fix the "UPPER END POSITION":

WARNING: in case the installer needs to modify this end-stop, it is allowed to lower the closed stop position. **Do not try to high the upper end-stop because this will cause severe damages to the product and invalidate warranty on the lift.**

- Turn the screw on the motor shown on the picture, clockwise to lower the lift.

In order to fix the "LOWER END STOP POSITION":

- Turn the screw on the motor, as shown on the picture, anticlockwise to increase the bottom stop point and clockwise to reduce it.

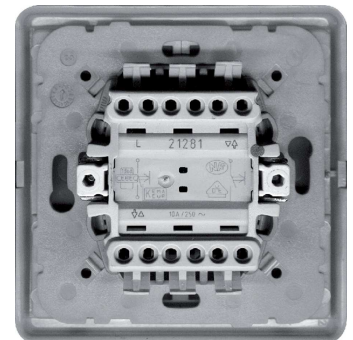
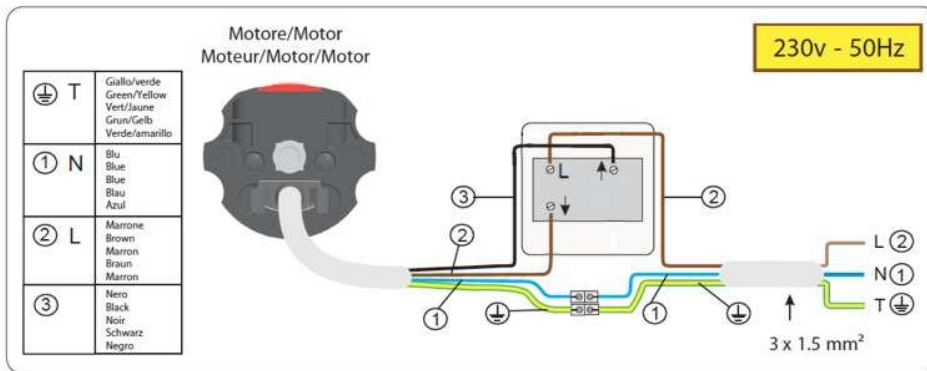

PICTURE 2D

Once you have fixed the "UPPER END STOP POSITION", mount the four sliding brackets with their screws under the lift frame (see PICTURE 3A). If necessary, the four sliding brackets can be angled in the desired direction. If necessary, cut the threaded bars to the desired length. Mount the bars to the sliding brackets using the supplied screws as shown in PICTURE 3B. On the false ceiling plate (not supplied), fix in the right position the four blind screws or the four bushes provided (point J of the supplied equipment list). At this point, fix the false ceiling plate to the four threaded bars (see PICTURE 3C)



PICTURE 3A



PICTURE 3B



PICTURE 3C

If the lift does not line up horizontally to the false ceiling, modify the length of the bars or the "UPPER END STOP POSITION", following the instructions above described. The signal and power cables should run inside the cable management system supplied. Open the sleepers that form the links of the chain and place the cables inside as shown below. (Pictures 4A and 4B)



PICTURE 4A



PICTURE 4B

TECHNICAL SPECIFICATIONS

POWER SUPPLY	230 V 50 Hz
MAX CONSUMPTION	156 W
TORQUE	10 Nm
MOTOR SPEED	17 Rpm
DIMENSIONS LIFT CLOSED	576X145X555 mm. (WxHxD)
DIMENSIONS LIFT OPENED	576X960X555 mm. (WxHxD)
GRILLE TOTAL DIMENSIONS	410x450 mm. (WxD)
MAXIMUM SIZE FIXING POINTS PROJECTOR	320x350 mm. (WxD)
MAXIMUM PROJECTOR DIMENSIONS	560X550 mm. (WxD)
MAXIMUM LOAD	15 KG.
NET WEIGHT OF PROJECTOR LIFT	12 KG.
CABLE GATHERING SYSTEM	20x18 mm. (WxH)

TECHNICAL DRAWINGS

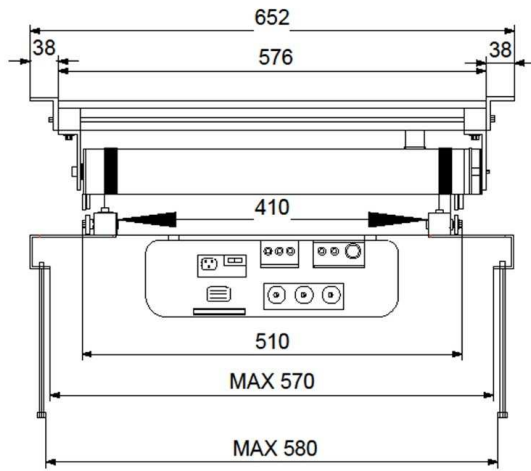

CLOSED LIFT: FRONTAL VIEW

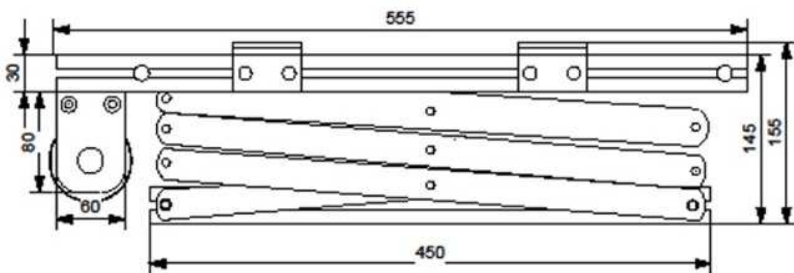

CLOSED LIFT: SIDE VIEW

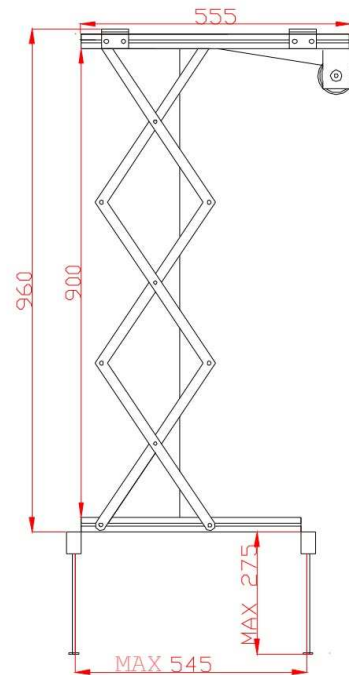

OPEN LIFT: SIDE VIEW

All measures are expressed in millimetres