

► Features

- Protects & transports up to 10 units of 19" equipment
- 335 mm usable depth
- Detachable front & rear cover
- ProShield™ Heavy duty top layer
- High quality 9 mm plywood
- Hardware by penn-ELCOM®
- Dual perforated rack rail on front side
- Punched square holes for use with snap-in cage nuts

► Description

The FCX110 is a 10 unit professional double cover flightcase compliant to the ANSI/EIA RS-310D, DIN41491 and IEC60297 standards for 19" equipment installation.

The construction is made out of high quality 9 mm plywood covered by a ProShield™ top layer, offering an optimal protection for your equipment. Both front and back lids are detachable, allowing instant access to both controls and connections of your equipment. Mounting of the equipment can be done using the perforated rack rail with punched square holes for use with snap-in cage nuts.

Superior durability and handling convenience is guaranteed through Penn-Elcom® hardware such as heavy-duty ball corners, rivet protected recessed flip handles and MOL™ type butterfly latches.



penn-ELCOM®

► Technical Drawing

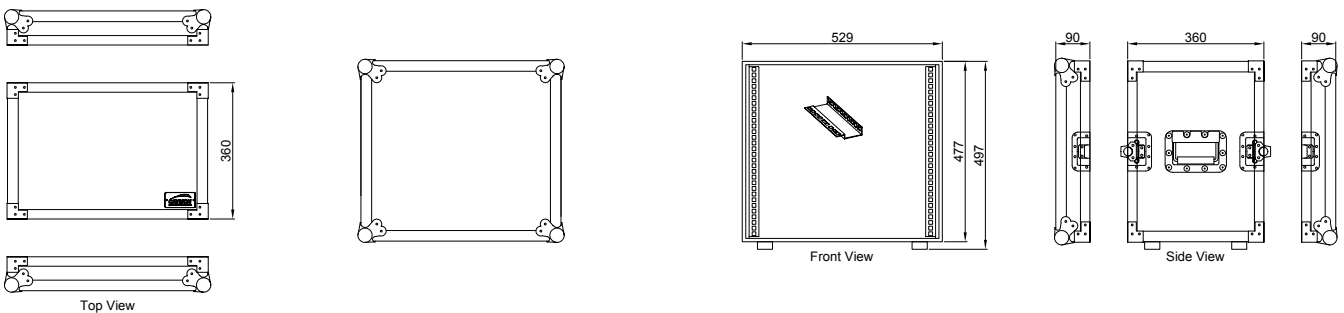

► Specifications

PROPERTY	VALUE
Unit height	10 HE
Width	529 mm
Height	477 mm (excl rubber feet)
Depth	540 mm (incl covers)
Tunnel depth	360 mm (excl covers)
Max usable depth	335 mm
Weight	17.8 Kg
Construction	9 mm high-quality plywood
Finishing	ProShield™ top layer
Handles	2 x Medium heavy-duty (H7154Z)
Butterfly latches	2 x Medium MOL™ (L907/928/10)

► Optional Accessories

ARTICLE	DESCRIPTION
KM500	M5 Cage nut
KS600	M5 x 16 mm bolt DIN7985 Black
KM600	M6 Cage nut
KS600	M6 x 16 mm bolt DIN7985 Black
BSFxxx	19" blind panels (1 to 6U)
BSVxxx	19" ventilated blind panels (1 to 6U)

Wide range of 19" accessories on www.caymon.eu