

DL107 NET, DL107 NET D
DL207 NET, DL207 NET D
DL210 NET 2.0, DL210 NET D 2.0
Digi-Loop® DSP Induction Loop Amplifiers

INSTALLATION MANUAL



DL107 NET, DL107 NET D



DL207 NET, DL207 NET D



DL210 NET 2.0, DL210 NET D 2.0

Table of Contents

Safety Warnings and Instructions	4
Avertissements et instructions de sécurité	5
How to Read this Manual	6
Amplifier Overview	6
Main Features (these vary by model)	7
Getting started: Connecting the amplifier	8
Rear connectors	9
Rack Installation	10
Ethernet Wiring	10
Using the Dante Audio Input	11
Dante jack LED indication (this differs from standard ethernet).	11
Analog Audio Input Connections	12
Loop Fault Relay Overview	12
DL107/207 Loop Fault Relay Connections	13
DL210 2.0 Loop Fault Relay connections	13
Loop Wire Selection	13
Powering Up	14
Initial Conditions	14
Loop Termination Warnings	14
Checking and updating firmware	15
To check the firmware version on the amplifier:	15
To update the firmware on the amplifier:	15
Installing and configuring the PC App	16
Ethernet Control Setup	17
USB Control Setup	18
Calibrating & commissioning the loop amplifier	19
Appendices	23
Maintenance & cleaning	23
General Troubleshooting	23
Troubleshooting a firmware update failure	23
PC App Detail	24
Front LCD Menu	29
Specifications	37
Resources	39
Warranty	39

Williams AV recommends that this equipment be installed by a qualified installer.

This is a person who has taken an Advanced Loop Class.

We recommend the Williams AV Advanced Loop Class, because it includes specific information about Williams AV Loop Amplifiers in the designing, installing and commissioning of loop systems.

Safety Warnings and Instructions

WARNING! TO REDUCE THE RISK OF FIRE OR ELECTRIC SHOCK, DO NOT EXPOSE THIS APPLIANCE TO RAIN OR MOISTURE.

CAUTION! TO REDUCE THE RISK OF ELECTRIC SHOCK, DO NOT REMOVE COVER. NO USER-SERVICEABLE PARTS INSIDE. REFER SERVICING TO QUALIFIED SERVICE PERSONNEL.



This symbol on the amplifier is intended to alert the user to the presence of un-insulated “dangerous voltage” within the products enclosure that may be of sufficient magnitude to constitute a risk of electric shock to persons.



This symbol on the amplifier is intended to alert the user to the presence of important operating and maintenance (servicing) instructions in the literature accompanying the appliance.

POWER CORD NOTICE FOR INTERNATIONAL OPERATION - Please call Williams AV Customer Service at 800.328.6190 to order the appropriate power cord for the country of use.

Important Safety Instructions:

1. Read these instructions
2. Keep these instructions
3. Heed all warnings
4. Follow all instructions
5. Do not use this apparatus near water.
6. Clean only with dry cloth.
7. Do not block any ventilation openings. Install in accordance with the manufacturer’s instructions.
8. Do not install near any heat sources such as radiators, heat registers, stoves, or other apparatus (including amplifiers) that produce heat.
9. Do not defeat the safety purpose of the polarized or grounding-type plug. A polarized plug has two blades with one wider than the other. A grounding type plug has two blades and a third grounding prong. The wide blade or the third prong is provided for your safety. If the provided plug does not fit into your outlet, consult an electrician for replacement of the obsolete outlet.
10. Protect the power cord from being walked on or pinched particularly at plugs, convenience receptacles, and the point where they exit from the apparatus.
11. Only use attachments/accessories specified by the manufacturer.
12. Unplug this apparatus during lightning storms or when unused for long periods of time.
13. Refer all servicing to qualified service personnel. Servicing is required when the apparatus has been damaged in any way, such as power-supply cord or plug is damaged, liquid has been spilled or objects have fallen into the apparatus, the apparatus has been exposed to rain or moisture, does not operate normally, or has been dropped.
14. The apparatus shall not be exposed to dripping or splashing and that no objects filled with liquids, such as vases, shall be placed on the apparatus.
15. Carts and Stands - The appliance should be used only with a cart or stand that is recommended by the manufacturer. An appliance and cart combination should be moved with care. Quick stops, excessive force and uneven surfaces may cause the appliance and cart combination to overturn.

16. Wall or ceiling Mounting - The appliance should be mounted to a wall or ceiling only as recommended by the manufacturer.

17. Power Sources - The appliance should be connected to a power supply only of the type described in the operating instructions or as marked on the appliance.

18. Object and Liquid Entry - Care should be taken so that objects do not fall and liquids are not spilled into the enclosure through the openings.

19. Servicing - The user should not attempt to service the appliance beyond that described in the operating instructions. All other servicing should be referred to qualified service personnel.

Precautions:

1. Power – WARNING, BEFORE TURNING ON THE POWER FOR THE FIRST TIME, READ THE FOLLOWING SECTION

CAREFULLY. The amplifier is designed for use only with the line cord of the region in which it will be operated.

2. Voltage Label (Rear Panel) – A label located at the rear panel power connection indicates the AC power input for the unit. The label will read 100-240V AC 50-60Hz 210W Auto-switching.

3. Do Not Plug in the input, output, ethernet, or USB connections while the power switch is switched to the “ON” position.

4. Do Not Touch the DL107/207/210 with wet hands. Do not handle the DL107/207/210 or power cord when your hands are wet or damp. If water or any other liquid enters the DL107/207/210 cabinet, take the DL107/207/210 to qualified service personnel for inspection.

5. Place the DL107/207/210 in a well, ventilated location. Take special care to provide plenty of ventilation on all sides of the DL107/207/210 especially when it is placed in an audio rack. If ventilation is blocked, the DL107/207/210 may over heat and malfunction. Do not expose the DL107/207/210 to direct sun light or heating units as the DL107/207/210 internal components temperature may rise and shorten the life of the components. Avoid damp and dusty places.

6. Care – From time to time you should wipe off the front and side panels and the cabinet with a soft cloth. Do not use rough material, thinners, alcohol or other chemical solvents or cloths since this may damage the finish or remove the panel lettering.

Avertissements et instructions de sécurité

AVERTISSEMENT! POUR RÉDUIRE LES RISQUES D'INCENDIE OU DE CHOC ÉLECTRIQUE, NE PAS EXPOSER CET APPAREIL À LA PLUIE OU À L'HUMIDITÉ.

MISE EN GARDE! POUR RÉDUIRE LE RISQUE DE CHOC ÉLECTRIQUE, NE PAS RETIRER LE COUVERCLE. L'APPAREIL NE CONTIENT AUCUNE PIÈCE RÉPARABLE PAR L'UTILISATEUR. CONFIER LES RÉPARATIONS À UN RÉPARATEUR QUALIFIÉ.



Le symbole  sur l'amplificateur est destiné à alerter l'utilisateur de la présence d'une tension dangereuse non isolée dans le boîtier du produit, qui peut être d'une amplitude suffisante pour constituer un risque d'électrocution.



Le symbole  sur l'amplificateur est destiné à alerter l'utilisateur de la présence d'instructions de fonctionnement et de maintenance (entretien) importantes dans la documentation accompagnant l'appareil.

AVIS CONCERNANT LE CORDON D'ALIMENTATION POUR UNE UTILISATION HORS DES ÉTATS-UNIS – Prière d'appeler le service à la clientèle de Williams AV au 800.328.6190 pour commander le cordon d'alimentation adapté au pays dans lequel l'appareil va être utilisé.

Consignes de sécurité importantes :

1. Lire ces instructions
2. Conserver ces instructions
3. Respecter tous les avertissements
4. Suivre toutes les instructions
5. Ne pas utiliser cet appareil à proximité d'eau.
6. Nettoyer avec un chiffon sec uniquement.
7. Ne pas bloquer les événements de ventilation. Installer conformément aux instructions du fabricant.
8. Ne pas installer à proximité de sources de chaleur telles que radiateurs, registres de chaleur, cuisinières ou autres appareils (y compris les amplificateurs) qui produisent de la chaleur.
9. Ne pas supprimer ou contourner la fonction de sécurité de la fiche polarisée ou de mise à la terre. Une fiche polarisée a deux broches dont l'une est plus large que l'autre. Une fiche de mise à la terre a deux broches et une troisième broche de mise à la terre. La lame large ou la troisième broche est fournie à des fins de sécurité. Si la fiche fournie ne rentre pas dans la prise, consulter un électricien pour le remplacement de la prise obsolète.
10. Protéger le cordon d'alimentation contre tout piétinement ou pincement, en particulier au niveau des fiches, des prises de courant et de l'endroit où il sort de l'appareil.
11. Utiliser uniquement les pièces/accessoires spécifiés par le fabricant.
12. Débrancher cet appareil pendant les orages ou lorsqu'il n'est pas utilisé pendant de longues périodes.
13. Confier toute réparation à un réparateur qualifié. Une réparation est nécessaire lorsque l'appareil a été endommagé de quelque manière que ce soit, par exemple si le cordon d'alimentation ou la fiche sont endommagés, du liquide a été renversé, des objets sont tombés dans

l'appareil, et si l'appareil a été exposé à la pluie ou à l'humidité, ne fonctionne pas normalement ou a chuté.

14. L'appareil ne doit pas être exposé à des gouttes ou des éclaboussures et aucun objet rempli de liquide, tel qu'un vase, ne doit être placé sur l'appareil.

15. Chariots et supports - L'appareil doit uniquement être utilisé avec un chariot ou un support recommandé par le fabricant. L'ensemble appareil et chariot doit être déplacée avec précaution. Des arrêts rapides, une force excessive et des surfaces inégales peuvent provoquer le renversement de l'appareil et du chariot.

16. Montage mural ou au plafond - L'appareil doit être monté sur un mur ou un plafond uniquement selon les recommandations du fabricant.

17. Sources d'alimentation - L'appareil doit être connecté à une alimentation électrique uniquement du type décrit dans le mode d'emploi ou tel qu'indiqué sur l'appareil.

18. Pénétration d'objets et de liquides - Des précautions doivent être prises pour que des objets ne tombent pas et que des liquides ne soient pas renversés dans le boîtier par les ouvertures.

19. Réparation et entretien - L'utilisateur ne doit pas tenter de réparer l'appareil autrement que de la manière décrite dans le mode d'emploi. Toute autre tâche d'entretien ou de réparation doit être confiée à un technicien qualifié.

Précautions :

1. Alimentation – AVERTISSEMENT : AVANT DE METTRE L'APPAREIL EN MARCHÉ POUR LA PREMIÈRE FOIS, LIRE SOIGNEUSEMENT LA SECTION QUI SUIT. L'amplificateur est conçu pour être utilisé uniquement avec un cordon d'alimentation adapté à la région dans laquelle il sera utilisé.
2. Étiquette de tension (panneau arrière) - Une étiquette située au niveau du raccordement électrique sur le panneau arrière indique la puissance consommée CA de l'appareil. L'étiquette indiquera 100-240 VCA 50-60 Hz 210 W à commutation automatique.
3. Ne pas brancher les connexions d'entrée, de sortie, Ethernet ou USB lorsque l'interrupteur d'alimentation est sur la position de marche.
4. Ne pas toucher le DL107/207/210 avec les mains mouillées. Ne pas manipuler le DL107/207/210 ou le cordon d'alimentation avec les mains mouillées ou humides. Si de l'eau ou tout autre liquide pénètre dans l'armoire du DL107/207/210, confier l'appareil à un technicien qualifié pour inspection.
5. Placer le DL107/207/210 dans un endroit bien ventilé. Veiller tout particulièrement à assurer une ventilation suffisante de tous les côtés du DL107/207/210, en particulier lorsqu'il est placé dans un rack audio. Si la ventilation est bloquée, le DL107/207/210 peut surchauffer et dysfonctionner. Ne pas exposer le DL107/207/210 à la lumière directe du soleil ou à des appareils de chauffage, car la température des composants internes du DL107/207/210 pourrait augmenter et réduire la durée de vie des composants. Éviter les endroits humides et poussiéreux.
6. Entretien - De temps en temps, essuyer les panneaux avant et latéraux et le boîtier avec un chiffon doux. Ne pas utiliser un matériel abrasif, des diluants, de l'alcool ou d'autres solvants ou chiffons contenant des produits chimiques, au risque d'endommager la finition ou d'effacer les indications fournies sur le panneau.

Firmware Disclaimer

This product includes the lwIP TCP/IP stack and the Deltatee tftp_server module. To comply with the terms of the licenses for these items, we must provide you with the following information.

lwIP TCP/IP stack: Copyright (c) 2001-2004 Swedish Institute of Computer Science. All rights reserved.

Deltatee tftp_server module: Copyright (c) Deltatee Enterprises Ltd. 2013. All rights reserved.

Both items are licensed under the following terms.

Redistribution and use in source and binary forms, with or without modification, are permitted provided that the following conditions are met:

1. Redistributions of source code must retain the above copyright notice, this list of conditions and the following disclaimer.
2. Redistributions in binary form must reproduce the above copyright notice, this list of conditions and the following disclaimer in the documentation and/or other materials provided with the distribution.
3. The name of the author may not be used to endorse or promote products derived from this software without specific prior written permission.

THIS SOFTWARE IS PROVIDED BY THE AUTHOR "AS IS" AND ANY EXPRESS OR IMPLIED WARRANTIES, INCLUDING, BUT NOT LIMITED TO, THE IMPLIED WARRANTIES OF MERCHANTABILITY AND FITNESS FOR A PARTICULAR PURPOSE ARE DISCLAIMED. IN NO EVENT SHALL THE AUTHOR BE LIABLE FOR ANY DIRECT, INDIRECT, INCIDENTAL, SPECIAL, EXEMPLARY, OR CONSEQUENTIAL DAMAGES (INCLUDING, BUT NOT LIMITED TO, PROCUREMENT OF SUBSTITUTE GOODS OR SERVICES; LOSS OF USE, DATA, OR PROFITS; OR BUSINESS INTERRUPTION) HOWEVER CAUSED AND ON ANY THEORY OF LIABILITY, WHETHER IN CONTRACT, STRICT LIABILITY, OR TORT (INCLUDING NEGLIGENCE OR OTHERWISE) ARISING IN ANY WAY OUT OF THE USE OF THIS SOFTWARE, EVEN IF ADVISED OF THE POSSIBILITY OF SUCH DAMAGE.

How to Read this Manual

The purpose of this manual is to give you supporting documentation for the commissioning of a loop system. You must first (1) connect the amplifier, (2) calibrate the amplifier to the loop wire(s) and then (3) adjust the output frequency response and automatic gain to be as flat and consistent as possible. The goal is to meet the IEC Specification for loop systems. It is highly recommended to take an advanced loop class prior to installation as commissioning is an involved process.

The manual is organized as follows:

Amplifier overview	Describes the purpose of this manual, amp models & features, and basic commissioning steps
Getting started: Connecting the Amplifier	Rear panel jacks, typical connections, do's and don'ts
Checking and updating Firmware	Checking version, downloading and upgrading firmware
Installing the PC App	Downloading and installing the PC App
Calibrating and Commissioning	Configuring the amplifier to work with the loop wires
Appendices	Maintenance and cleaning. Resources. Front Panel Controls Reference PC App Reference Specifications Warranty

Amplifier Overview

Thank you for purchasing the DL107/207/210 Digi-Loop™ DSP Induction Loop Amplifier. Williams Sound loop amplifiers deliver the latest in induction loop technology, and provide integrated DSP audio processing with flexible user control.

Depending on model, the amplifiers accept input(s) of analog, mic or line level, balanced unbalanced, or optional Dante digital.

Control is carried out using the on-board LCD menu (GUI) display and control knob, or via the PC App installed on Windows-based devices (Windows PC or Surface Tablet).

The DL207 and DL210 models can drive two induction loops or a phased-array. The DL210 models can drive an 8-ohm speaker in place of one loop, if desired. The D107 can drive a single loop only.

The range of loop amplifier models have a variety of options to suit a wide variety of installation requirements.

	DL107 NET	DL107 NET D	DL207 NET	DL207 NET D	DL210 NET 2.0	DL210 NET D 2.0
Input: Mic/Line	1	1	1	1	2	2
Input: Line	1	1	1	1	2	2
Input: 70-100 Volt	1	1	1	1	1	1
Input: Dante™		1		1		1
Output: Loop	1	1	2 (dual or phased array)	2 (dual or phased array)	2 (dual or phased array)	2 (dual or phased array)
Loop Output Power:	9.5 Arms/13.4 Apk 16.1 Vrms/22.8 Vpk	9.5 Arms/13.4 Apk 16.1 Vrms/22.8 Vpk	9.5 Arms/13.4 Apk 16.1 Vrms/22.8 Vpk	9.5 Arms/13.4 Apk 16.1 Vrms/22.8 Vpk	12 Arms/17 Apk 33.3 Vrms/47.6 Vpk	12 Arms/17 Apk 33.3 Vrms/47.6 Vpk
Output: Line	1	1	1	1	2	2
Output: Headphone	1	1	1	1	1	1
Output: Speaker					1 (swap loop A)	1 (swap loop A)
Network Control	x	x	x	x	x	x

All of these models conform to IEC 62489-1 Benchmark Testing Specifications.

Main Features (these vary by model)

- Active protection against short and open circuits (all models)
- Power-save mode (all models)
- Fan-cooled, temperature regulated (all models)
- High output current:
 - 9.5 A x1: DL107
 - 9.5 A x2: DL207
 - 12.0 A x2: DL210 2.0
- Speaker output (DL210 2.0 only)
- Input configurable as microphone input or line input, balanced or unbalanced:
 - XLR: DL210 2.0
 - 3-position terminal block: DL107/207
- Meets ADA/ADAAG Guidelines (all models)
- Remote Monitoring Support (all models)
- 2 year Warranty (all models)
- Master gain Control (all models)
- Active protection against shorted or open loops (all models)
- Loop-through Line Output (all models)
- Pink Noise (all models)
- Priority Input (all models)
- Standard 19" rack mount:
 - 1RU: DL107, DL207
 - 2 RU: DL210 2.0

Ideal applications for loop systems

- Courtrooms
- House of Worship
- Hearing Assistance
- Conference Rooms

Getting started: Connecting the amplifier

Connection Diagram

The following diagram provides an overview of typical connections. Connect the amplifier as required for your installation. The amplifier must be connected to the load (loop wire) prior to powering it on. If it is not, it will present a “fault” message and shut down.

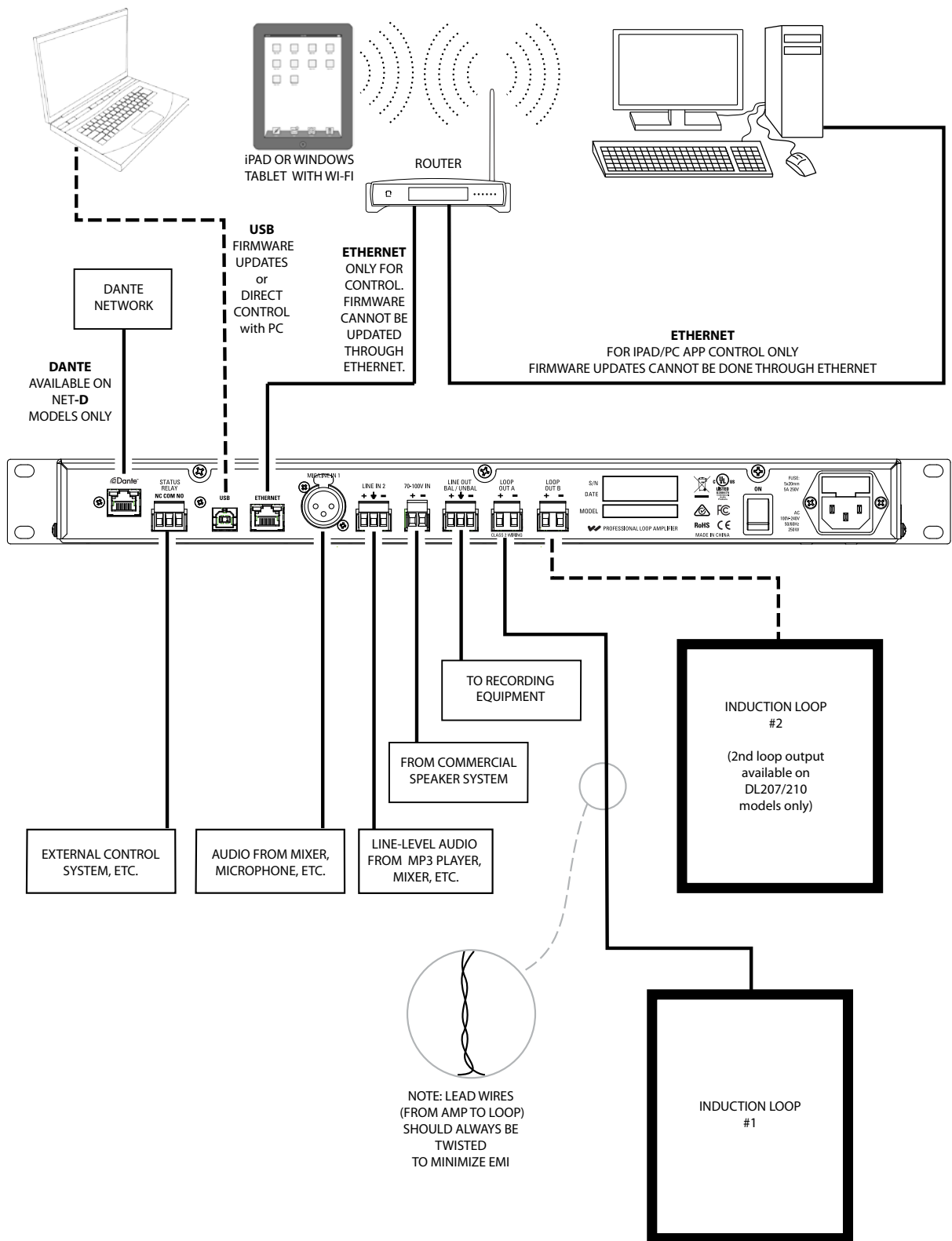

Rear connectors

Rear Panel (DL107 NET D shown)

DL107

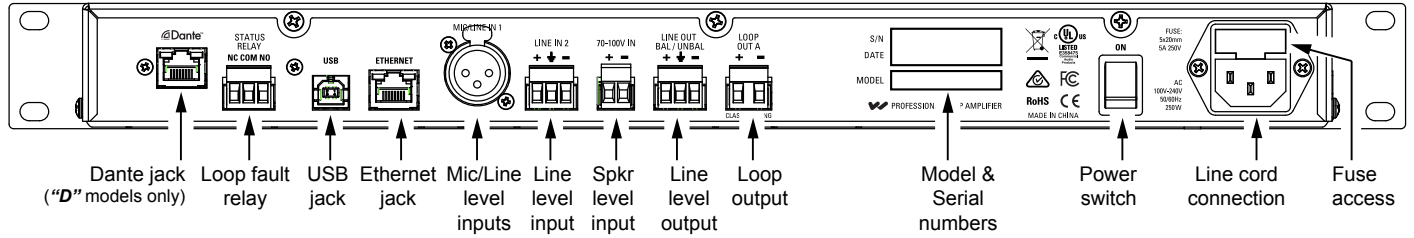

Rear Panel (DL207 NET D shown)

DL 207

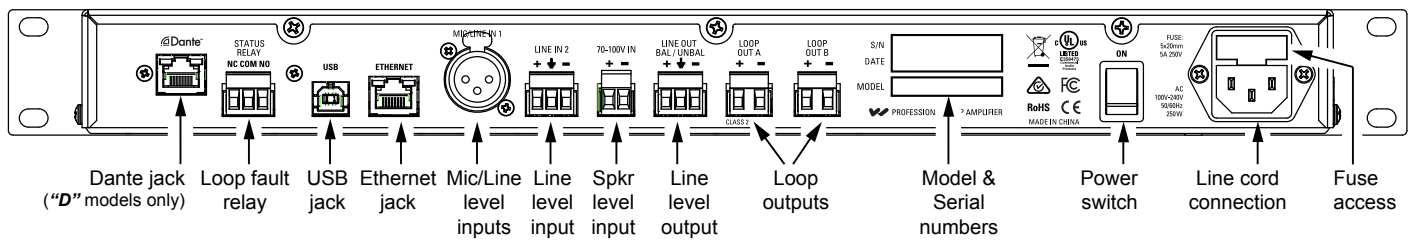

Rear Panel (DL210 NET D 2.0 shown)

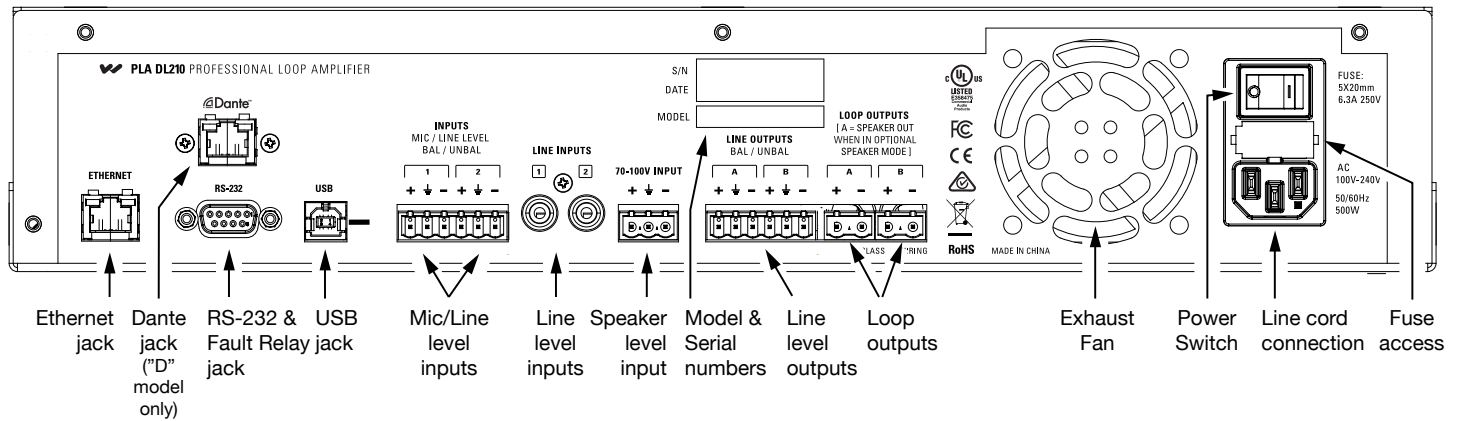

The following table provides a quick reference to each connector's use and configuration adjustments.

Input	Connector	Configuration/Control
Mic/Line (balanced or unbalanced)	terminal block	Mic Gain: +9 dB to +63 dB (48v phantom power) Line levels: -10 dBU, -4 dBU, +4 dBU, +8 dBU 48v Phantom Power
Unbalanced Line	RCA	-10 dBV
70-100 Volt	terminal block	-
Dante™	RJ-45	-

Control	Connector	Purpose
Ethernet	RJ-45	Control and monitoring over the network using PC App or MLM
USB	USB-B (versions 1.1, 2.0 or 3.0 supported)	Firmware Updates, Control by PC App
RS-232	DB-9	loop fault relay output

Output	Connector	x
Line level	terminal block	mirrors the audio of the loop outputs +4 dBU, balanced or unbalanced
Loop	terminal block	12 Arms/17 Apk, 33Vrms/471 Vpk, 0.5 to 3.0 Ω dc
Speaker	terminal block output A (configurable)	125 W @ 8Ω

Rack Installation

1. Install into a 19" rack using standard 10-32 rack screws.
2. Leave 1U rack space above for ventilation.
3. A surge protector or power conditioner is highly recommended.
4. Use a grounded outlet.
5. Connect all input/outputs before applying power.
6. Plug in the power cord and turn on the unit.

USB Cable Wiring

A standard USB cable (USB Male A to Male B) can be used to connect a computer (such as a laptop) to the Loop Amplifier directly for initial configuration. No drivers are necessary, simply plug-in a USB cable, open the PC App, specify USB connection, and the PC App can be used to change settings on the amplifier. *Note: Firmware upgrades can only be done through the USB connection. They cannot be performed through Ethernet.*

Ethernet Wiring

If connecting directly from a Computer to the Loop Amplifier, an Ethernet Crossover Cable must be used.

If connecting through a network, a standard ethernet cable must be used to connect the Amplifier to the network, and a standard ethernet cable must be used to connect the Computer to the network.

If a third party controller will be used (Crestron), a standard ethernet cable can be used to connect the amplifier and controller to the network.

Note: A standard ethernet cable is terminated with either T568A pinout on both ends, or T568B pinout on both ends. A crossover cable has T568A pinout on one end, and T568B pinout on the other end. See the internet for more information about terminating ethernet cables.

Using the Dante Audio Input

The DL107/207/210 NET “D” models provide a Dante RJ-45 network jack. The addition of the Dante jack enables a virtually unlimited number of digital audio sources to be routed and streamed to the amplifier.

To change the parameters of Dante (i.e. IP address, Dante Device Name) you must use the Dante Controller software on a PC. The Dante parameters can be viewed, but cannot be set, on the front LCD Display on the loop amplifier (or PC/iPad App). For more information on configuration and usage of *Dante Controller*, please visit Audinate’s website at: <https://www.audinate.com/products/software/dante-controller>.

Note: Dig In L and Dig In R are separate channels of audio. They can be used, for example, if two different audio programs are desired, Dig In L could be routed to one loop and Dig In R routed to the other loop. The mixer functions are used to route each channel to the desired loop. See the section “Input Configuration” for more information about configuring these inputs.

Format

Sample Rate: 44.1 & 48 kHz

Bit Depth: 24 bits

Dante network

Connect via Ethernet

Set the Dante ethernet settings in the server to

- Obtain an IP address automatically
- Obtain DNS server address automatically

Dante Controller

All Dante device setup and source routing is performed through Dante Controller. This includes the IP Address and Dante Device Name that appear in the loop amplifier “Net Info” screen. If a name change is desired, or the Dante IP Address needs to be set, refer to Dante Controller documentation. To view the amplifier settings configured by Dante Controller, go to “System Configuration - Tech Tools - Net Info” and scroll down to the Dante section.

The Dante jack LED indicators operate differently than standard ethernet jack LEDs. See illustration below.

Dante jack LED indication (this differs from standard ethernet).

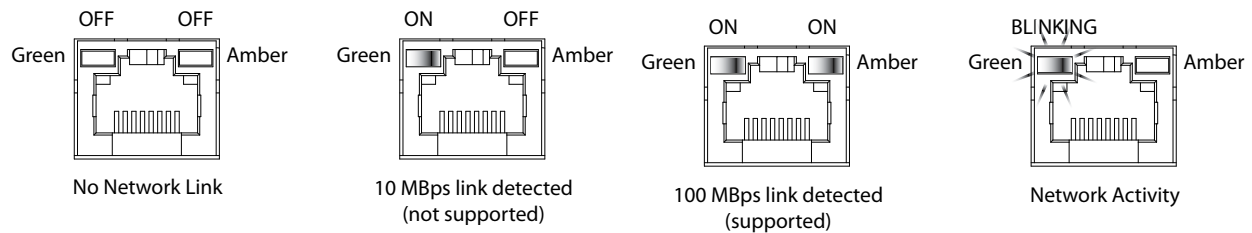

Analog Audio Input Connections

The DL107/207 amplifiers have an XLR Mic/Line input for accepting the balanced output of a microphone or mixer. These models also have a phoenix-block line input. The DL210 only has phoenix-block line level inputs. The following is how the phoenix blocks would be wired.

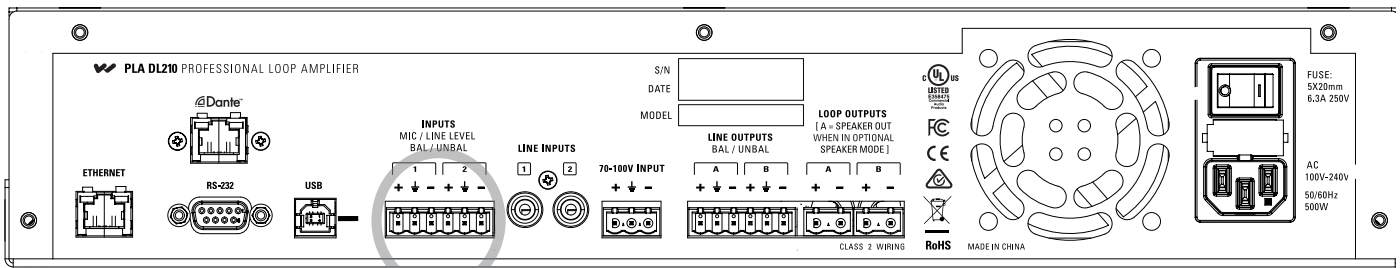

Yes

No

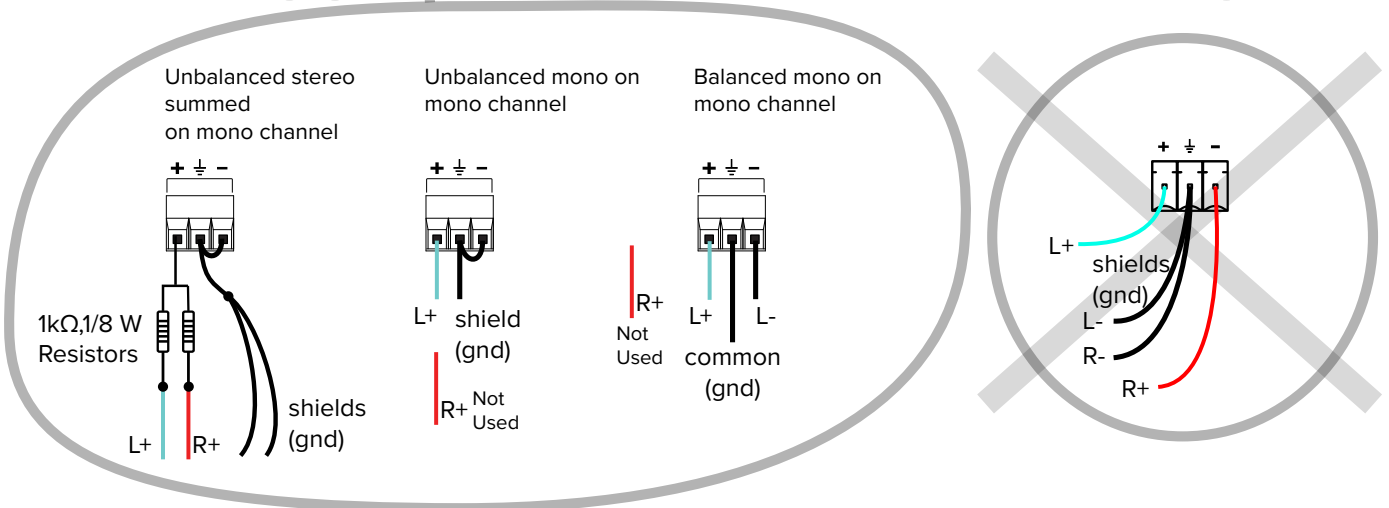

Unbalanced Sources

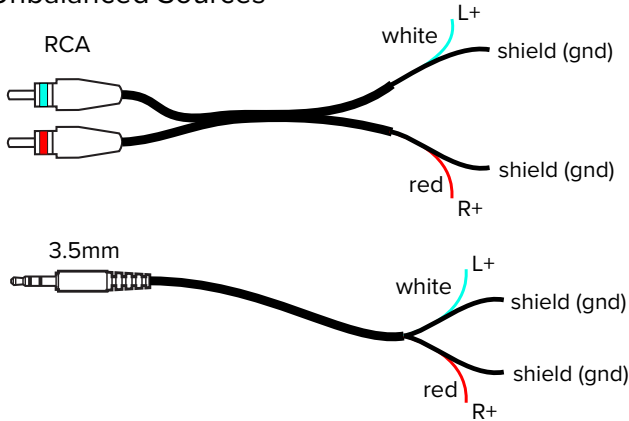

Balanced Sources

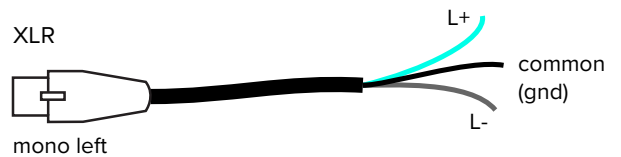

Loop Fault Relay Overview

The loop fault relay provides a NO (normally open) and NC (normally closed) contact closure for triggering an external device or control system when a fault (shorted or open loop) occurs. The external control system can then send a text or email, initiate an alarm, or turn on a light to let personnel know that a loop fault has occurred.

DL107/207 Loop Fault Relay Connections

The DL107/207 models provide a loop fault relay through a 3-position terminal block connection on the rear of the amplifier.



- Pin 1 - NC (Normally Closed)
- Pin 2 - Relay GND
- Pin 3 - NO (Normally Open)

DL210 2.0 Loop Fault Relay connections

The DL210 models provide the relay as part of the “RS-232” DB-9 connector. The relay and RS-232 use separate pins and are completely isolated.

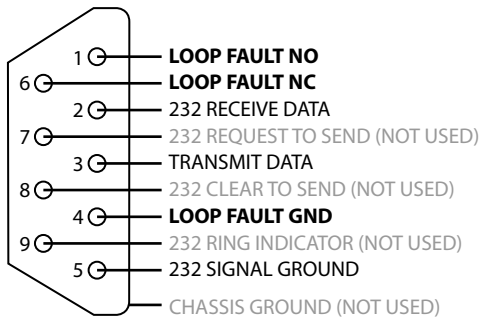

RS-232:

- Pin 2 - Receive
- Pin 3 - Transmit
- Pin 5 - Signal GND

Loop Fault:

- Pin 1 - Loop Fault NO
- Pin 4 - Ground
- Pin 6 - Loop Fault NC

Loop Wire Selection

To select the proper wire for the loop(s), refer to the following chart. Wire resistance of each loop needs to be 0.5 - 3.0 Ω as required by the amplifier.

Wire type	AWG / (CSA)	DC ρ per 1000 ft (305 m)	Max length Approx ft (m)	Min length Approx ft (m)
Single conductor	18 (0.82 mm ²)	6.4	234 (71 m)	78 (24 m)
	16 (1.3 mm ²)	4.2	360 (110 m)	120 (37 m)
	14 (1.9 mm ²)	2.4	630 (192 m)	210 (64 m)
	12 (3.3 mm ²)	1.5	1000 (305 m)	333 (101 m)
	10 (5.3 mm ²)	1.0	1500 (457 m)	500 (152 m)
Flat 3/4" copper	~14 (1.9 mm ²)	2.4	630 (192 m)	210 (64 m)

Powering Up

Connect the inputs and outputs as desired (referring to the last section). Make sure the loop wire resistance measures 0.5Ω - 3Ω. Connect the IEC power cable supplied, and power up the amplifier using the switch on the back panel.

Initial Conditions

The amplifier, out of the box, powers up with factory settings according to Table 1 and Table 2.

No input selection is necessary for an output to be heard if the source is connected to any of the inputs.

All inputs are initially routed to the loop outputs at a gain setting of -12 dB.

INITIAL INPUT SETTINGS

Input	Name	Type	Settings
1 & 2	Dig L/Dig R	Dante	-
3 & 4	Input 1/2	Mic/line, balanced or unbalanced	Line level, -10 dBU, phantom power OFF
5 & 6	Line 1/2	Unbalanced line	Line level, -10 dBU
7	70-100V	70/100 volt	Level: 25 Vrms

INITIAL OUTPUT SETTINGS

Output	Name	Mode	Settings
1	Loop A	DL107: Single Loop DL207/DL210: Dual Loop	all inputs are routed to this loop at -12 dB
2	Loop B	DL107: Single Loop DL207/DL210: Dual Loop	all inputs are routed to this loop at -12 dB
3	Line A	mirrors the audio of the loop outputs	
4	Line B	mirrors the audio of the loop outputs	

Loop Termination Warnings

After powering up, the unit will test the loop resistance. If the loop has not been terminated, or has an open circuit, a warning will pop up that the “Amplifier has shut down”. Push the “Adjust” button in to dismiss the warning. The Home Page loop status appears indicating “FAULT”. Periodically the previous warning pop up will reappear, requiring the operator to press enter again.

If this happens the loop wire resistance must be fixed. If the outputs are now terminated with the proper resistance, the amplifier will not automatically reset to operational status. The amplifier must be rebooted.

If a loop is disconnected from the amplifier, a warning will not come up. If the amplifier is rebooted, the warning will now appear.

To avoid warnings due to an open circuit, terminate the unused loop outputs with a resistor such as a 1Ω, 100 Watt resistor or similar.

Note: the amplifier runs a loop test each time it is powered up. So to recover from a fault condition the amplifier must be turned OFF then ON again.

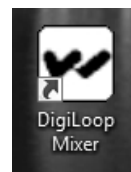
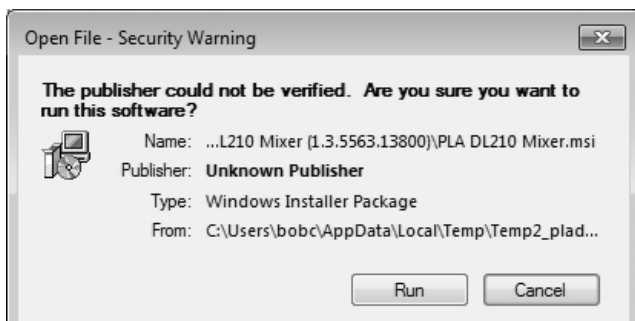

Checking and updating firmware

To check the firmware version on the amplifier:

By the time the amplifier is to be installed, the firmware may be out of date. The amplifier will not always arrive with the latest firmware version either. For best performance it is highly recommended to check & upgrade the firmware.

There are *two ways* to view the current firmware version on the unit:

1. Front LCD - During boot-up

Power ON the amplifier and watch the LCD screen. The firmware version is displayed after the 'w' logo is displayed, and before the loop status check and output VU meters are displayed.

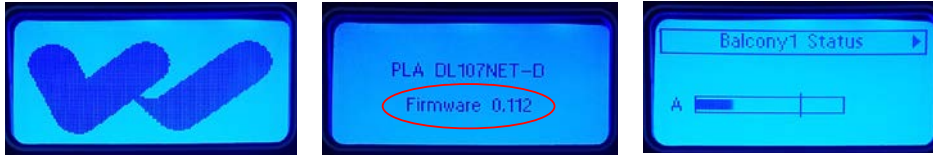

2. Front LCD - Version Info Screen

If the amplifier is already powered ON, it is easy to view the firmware version without shutting the amp OFF.

Using the LCD Menu control knob, navigate to System Configuration - Tech Tools - Version. The current version is displayed by "CPU:".

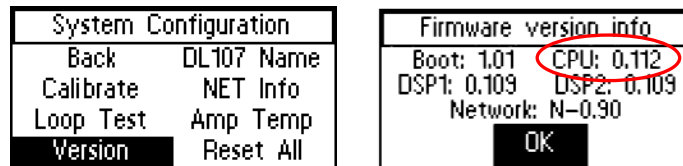

To update the firmware on the amplifier:

If a newer version of firmware exists on our website, use the steps listed on the firmware download page to upgrade the firmware in the amplifier.

There are two version of firmware - one for the 210 models and another for the 107/207 models. Take care to download the correct version!

Installing and configuring the PC App

The PC App is used to configure and commission the amplifier.

When configuring the amplifier, the ethernet connection is recommended for best performance (**crossover cable required**).

*The ethernet connection cannot be used for firmware updates. **The USB port must be used for firmware updates.***

The USB port can be used with the PC App, but performance may be limited.

Hardware Requirements:

Desktop/Laptop Computer	Windows PC. Mac PC not supported.
Mobile Device	Windows Surface Tablet. iPad, iPad Mini and Android not supported.
Operating System Compatibility	Windows XP Windows Vista Windows 7 Windows 8 Windows 10 Microsoft .NET 4.0.30319 minimum.
Ethernet	10/100 GB Standard RJ-45 jack.
USB	1.1 2.0 (12 MBs high speed) 3.0 (5 GBs super speed); standard "B" jack.

To install the PC App:

Download the PC App by visiting our website www.williamsav.com and browse to **Support - Software**

Follow the instructions on the software download page to install the PC App. When the installation completes it will create this icon in the programs/apps directory:



Ethernet Control Setup

A **crossover ethernet cable** must be used when directly connecting a PC to the amplifier.

Before the PC App can be used, an IP Address must be assigned to the amplifier using the front LCD menu. The PC must have it's own unique IP address on the same subnet. Then the IP Address of the amplifier needs to be entered into the PC App.

Set an IP Address in the amplifier.

Using the front LCD menu on the amplifier, navigate to System Configuration - Ethernet.

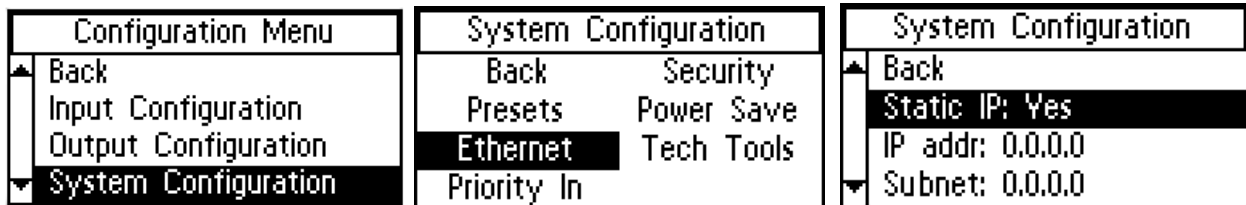

Fill in the settings below.

- Static IP: Yes
- IP Address: e.g., 192.168.100.127 (this address is only an example)
- Subnet: 255.255.255.0
- Telnet Port: 23

Set the networking properties on the computer to an unused static IP Address.

The static IP should be in the same subnet used in step 1. For this example, set the IP Address to 192.168.100.128. In Windows 10 this is configured under Network & Internet Settings - Ethernet - Change Adapter Options - (choose ethernet card) - (TCP/IPv4) Properties.

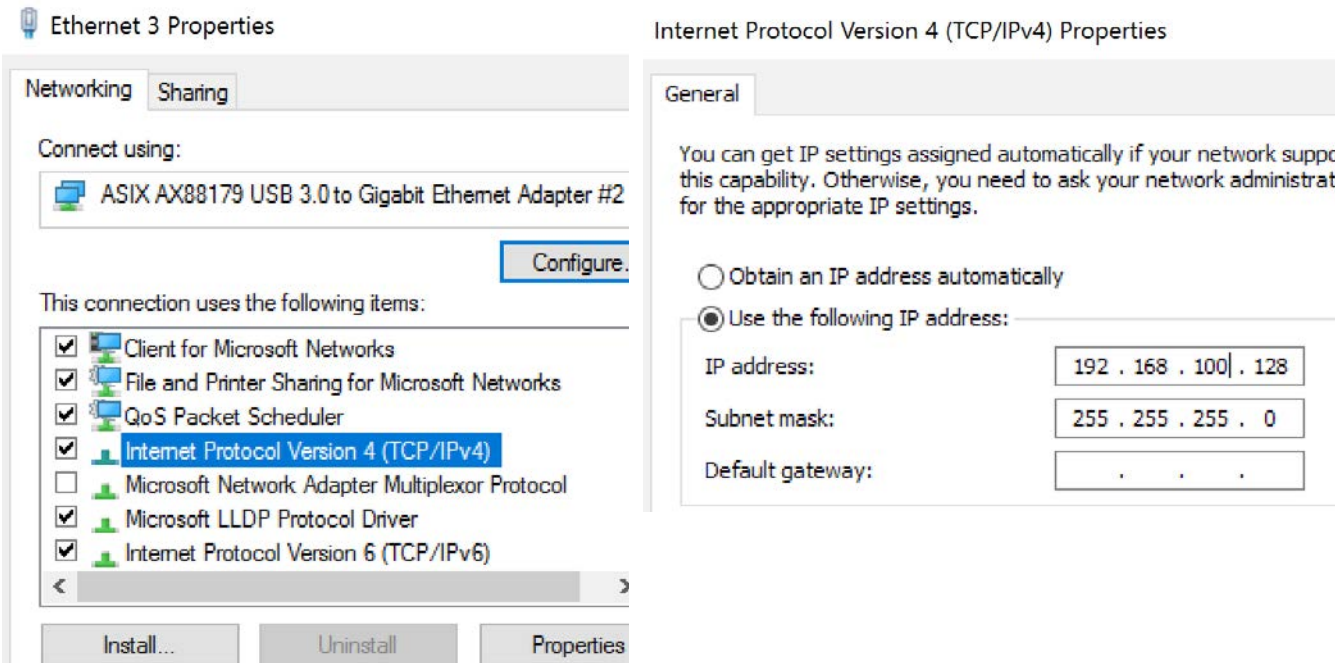

Set the amplifier IP Address in the PC App.

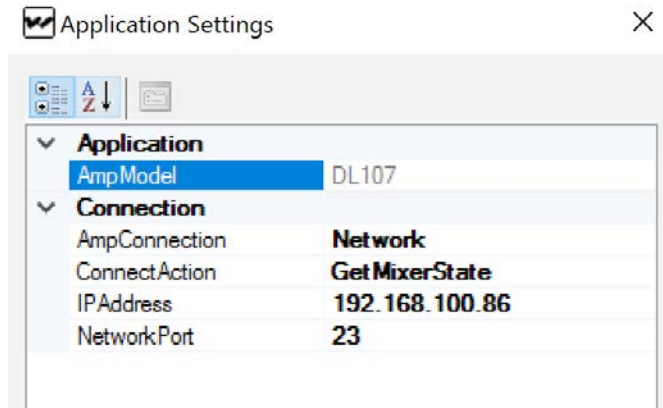

1. Select **AmpModel** from the dropdown list (e.g., DL107, DL207, DL210 or DL210_20).
2. Set the **AmpConnection** to "Ethernet"
3. Set **ConnectAction** to "GetMixerState".
4. Set **IP Address** to the amplifier's IP Address (from step 1).

Click the amplifier "Connect" icon on the top left of the PC App Toolbar.

When the computer connects to the amplifier, the symbol will turn Green. If it cannot connect, it will turn Red. The sliders should move and the VU Meters should "pulse", indicating that the computer has pulled the current state information from the amplifier.

Amp symbol before connection attempt:



Turns GREEN when connected:



Turns RED if cannot connect:



If the symbol turned GREEN, you can now use the PC App.

Note: Under Ethernet control, the amplifier does not update the input levels adjusted by the App, until another function is carried out, such as pressing the Enter button or moving to another menu.

USB Control Setup

1. Connect the computer to the amplifier with a standard USB cable.
2. Open the PC Mixer App on the computer.
3. Under the settings tab icon on the top toolbar , set "AmpConnection" to "USB" and "ConnectAction" to "GetMixerState".
4. Power ON the amplifier.
5. Click the amplifier "Connect" icon on the top left of the PC App Toolbar.

When the computer connects to the amplifier, the symbol will turn Green. If it cannot connect, it will turn Red. The sliders should move and the VU Meters should “pulse”, indicating that the computer has pulled the current state information from the amplifier.

Amp symbol before connection attempt:



Turns GREEN when connected:



Turns RED if cannot connect:



If the symbol turned GREEN, the PC App is ready to use.

Note: If both channels aren't terminated with at least 0.5 ohms, the amplifier icon in the PC App may not turn green when trying to connect. If this happens you will need to fix the problem, disconnect the USB cord between the amplifier and computer, reboot the amplifier, reconnect the USB Cord and try to connect again.

If the PC App has detected a fault, such as Loop B not being terminated with at least 0.5 ohms, even when the amp is terminated and rebooted the PC App will still indicate “Loop B: Error” even though the amplifier does not indicate this fault. If this happens, perform a loop test from the toolbar to clear this condition. If the PC App still indicates “Loop B: Error” the PC App will need to be closed and re-opened to pull the new state information from the amplifier.

Calibrating & commissioning the loop amplifier

The loop amplifier must be calibrated to the field strength of the loop or the VU Meters and settings adjustments will not be accurate.

An external source (such as a test tone generator) CANNOT BE USED to calibrate the amplifier. The internal test tone generator MUST be used.

Calibration and commissioning are necessary to meet IEC Spec 60118-4.

Equipment required: Field Strength Meter, USB cable (or crossover ethernet cable), and windows-based PC.

Requirements:

- a Background Noise Check was performed with a field strength meter
- a Test Loop was verified with the amplifier connected
- the permanent loop wire(s) measure 0.5-3.0 ohms (including lead wires)
- the latest firmware is loaded in the amplifier
- the latest PC App is installed on the PC

1. Start communication between the PC App and Amplifier.

Refer to “USB Control Setup” for this example.

2. Load preset factory defaults for Loop type.

This clears previous settings and loads preconfigured factory settings for the loop type. The loop type is either a Single Loop, Dual Loop or Phased Array. The DL210 models offer a “Speaker + Loop” preset and this is used for a single loop. DL107/207 models have a “Single Loop” preset.

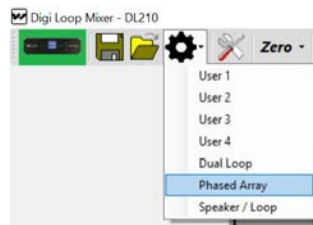

3. Calibrate the amplifier to a field strength of 400 mA/m at 1 kHz, with FSM 5 ft above floor.

a. Set FSM switches - top button depressed out “Norm”, bottom button pushed in “0dB”.

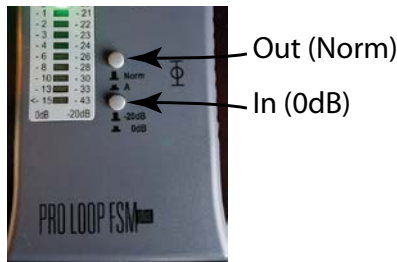

b. Set or hold the FSM at 5ft above the floor, in the center of the loop or array.

c. Open the Calibration Window in the PC App.

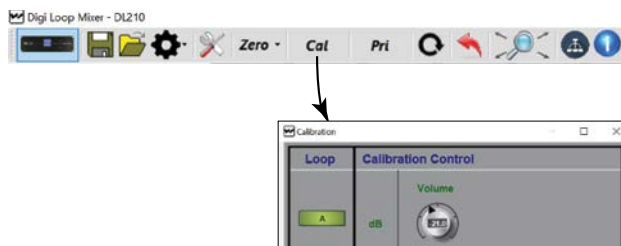

d. Set the Frequency to 1 kHz, and adjust the volume level until the Field Strength Meter reads 0 dB.

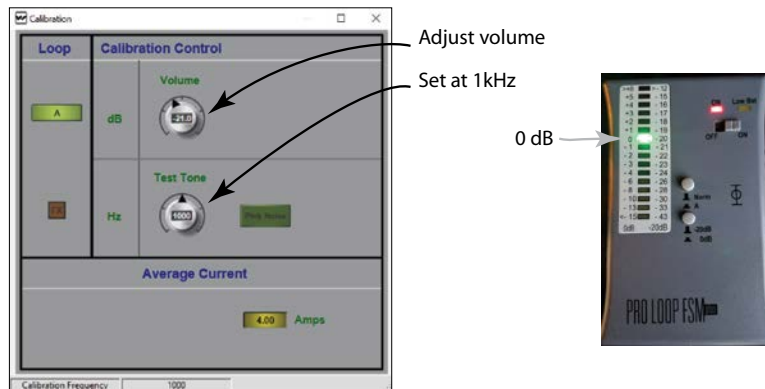

e. *For Phased-Array only:* Switch to Loop B (by clicking on the “A” button) and turn up the volume until the current for Loop B is close to Loop A (within 0.2A).

The loop amplifier is now calibrated. This is the 0 dB calibrated reference point that the EQ adjustments will reference. It also makes the Input and Output VU Meters accurate.

The volume adjustment in the Calibration Window (test tone) should not be changed after this. Doing this will take the amplifier out of calibration. The EQ adjustments in the next step have their own level adjustment controls.

If more output is desired from the loop, the Source volume should be adjusted first, then the Input Sliders, then the Output Effects AGC Control, in that order.

4. Equalize other frequencies to match the calibration point.

Make sure the switches on the field strength meter are in same position as they were for calibration.

Step a
Open the Effects Window

Step b
Bass=100 Hz,
Mid=500 Hz,
Treble=2500 Hz,
Metal Comp=5000 Hz

Step c
Return to the Calibration Window
and set the test tone for 100 Hz
(the first frequency to be equalized).

Step d
Return to the Effects Window
and adjust the EQ volume (dB) until
the field strength meter reads 0 dB.

Step e
Repeat Steps c & d for the next frequency,
(i.e. 500 Hz). Repeat c & d until each of the
frequencies have been equalized to 0 dB.

- Open the output EQ settings by clicking on the FX button in the Calibration Window.
- Set 4 equalizer frequencies, Bass=100 Hz, Mid=500 Hz, Treble=2500Hz, Metal Comp at 5000Hz.
- Return to the Calibration Window and set the test tone to 100 Hz. The amplifier is now generating 100 Hz in the loop.
- Go to the Output Effects Window and adjust the dB level until the field strength meter reads 0 dB. The loop is now equalized for 100 Hz.
- Repeat steps c & d for the next frequency (i.e. 500 Hz) and continue until each of the frequencies has been adjusted to 0 dB as measured by the field strength meter.

5. Test with an appropriate audio source (DO NOT USE an external test tone generator).

- Connect a source such as an MP3 player or smartphone to the Line 1 input.
- With music playing, observe the Loop Output VU meters on the PC App. They should be peaking around 0 dB.
- If the output level is not sufficient, adjust the Source Volume up.
- If the output level is still not sufficient, adjust the Input Slider up.
- If the output is still not sufficient, or if the performance is too dynamic, go into the Output Effects Window and adjust the AGC level up to about 5.

DO NOT go back into the calibration window and adjust the level. This will take the amplifier out of calibration!

6. Save configuration settings to a file



Save configuration settings to a file

- a. Use the Save icon in the PC App
- b. Save the file with the project name in the file name.
- c. **Do not** turn off the amplifier for at least 30 seconds after saving settings.

7. Optional - lock amplifier with a password.

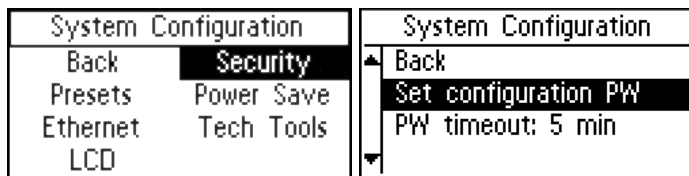

- a. Using the front dial on the amplifier, navigate to System Configuration - Security - Set configuration PW.
- b. Record the password somewhere for future reference.

Note this does not prevent the PC App from working - it just protects the unit from being tampered with through the front LCD Menu.

Appendices

Maintenance & cleaning

The Front Display should be cleaned with a clean, damp microfiber cloth only. This will prolong the life and legibility of the screen. To prevent scratching, do not use Windex or any other type of cleaner or cloth/paper towel on the screen.

The case can be blown out with compressed air and the outside wiped down with a damp cloth. Windex can be used on the case, as long as it is not used on the screen.

General Troubleshooting

Problem	Solution
No Sound	<ul style="list-style-type: none"> - Check to see that the loop amplifier is on. - Make sure the input source is on/playing. - On the “Loop Status” screen, the horizontal bar graph should be pulsing with the audio from the input source. - Plug in headphones and make sure the input source is producing audio. - Check loop connections - are both loop ends connected firmly and are the cable ends properly terminated with exposed wire in the contacts?
Interference / hum / background noise	<ul style="list-style-type: none"> - Are hearing aids/receivers on/set correctly? - Turn the loop system off and check to see if background noise remains. If it does, the noise may be created by other electrical systems and picked up by the loop. Turn off nearby appliances to find the source of the interference. - If a microphone is connected to the microphone input, try shutting off the microphone or unplugging it. If the noise goes away, turn it back on and try reducing the microphone input gain.
Announcements not heard on 70-100v input	<ul style="list-style-type: none"> - Is the announcement source on and working? Can announcements be heard on the 70-100 V speakers? - Check connections to the amplifier. Is the announcement source connected to the 70-100 V input? - If the announcement source is properly connected, and audio is very low, try increasing the input gain on the loop amplifier, or the output gain of the 70-100 V source. - With the 70-100 V input selected for the headphone jack, listen with a pair of headphones and verify that the input is receiving audio
Distorted audio	<ul style="list-style-type: none"> - Is the input level set correctly in the amplifier? (i.e. Mic/Line level, mic phantom power on/off, etc.) - Is the source level too high?
PC App not controlling the amplifier	<ul style="list-style-type: none"> - Is the IP address set correctly in the amplifier? (System Configuration-Tech Tools-Net Info) Note: the amplifier needs to be rebooted for the IP address to take effect. - Is the IP address assigned in the amplifier the same as the IP Address entered into the iPad/PC App? - Is the correct amplifier model selected in the iPad/PC App? - Is the amplifier communicating on the network? Can you ping the amplifier from a PC on the network? If not, check the ethernet path (cables, switches, router, etc).

Troubleshooting a firmware update failure

If the installation fails a dialog box will come up like this:

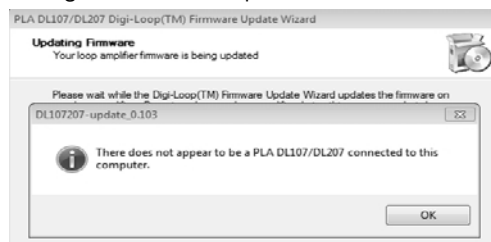

Generally, firmware updates fail because a connection between the computer and amplifier could not be established. This sometimes happens if either USB port was previously in use or connected to a device.

To re-install the firmware, follow these instructions ***in sequence***.

1. Unplug the ethernet and USB cables from the amplifier and computer.
2. Power OFF the amplifier.
3. Power OFF the computer. ***If the computer is already powered up, shut it down. Then power it on. (Do not just reboot)***. This clears any previously established telnet connections and makes the USB port ready for connection. Wait for the computer to completely boot into Windows.
4. Turn on the amplifier and wait for it to fully boot, showing the VU meters on the front LCD display.
5. Connect the USB cable from the computer to the amplifier.
6. Double-click on the firmware exe file to reinstall the firmware.

PC App Detail

PC APP TOOLBAR

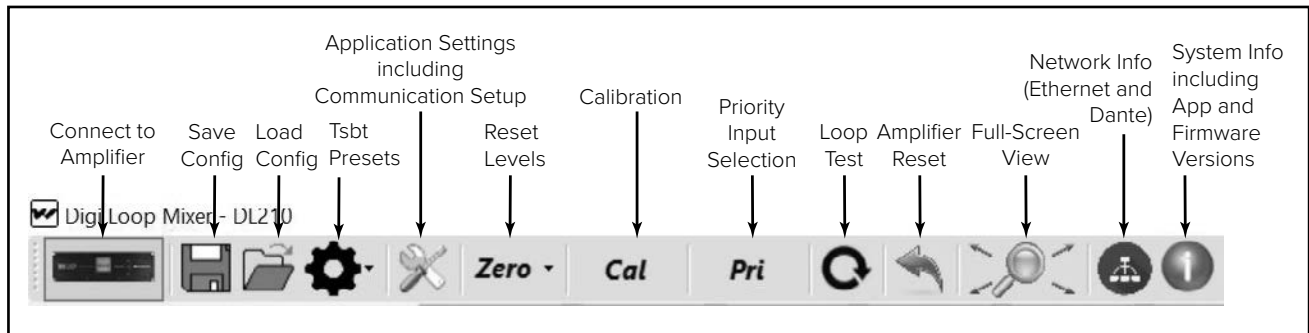

Connect to Amplifier - This symbol establishes connection between the amplifier and the PC. When connected, the indicator turns green.

Save Config - Stores all of the system settings in a file.

We recommend saving the settings in a file in case of power outage or other catastrophic failure. Settings should be saved immediately after the system is calibrated.

Load Config - Loads saved system settings from a file.

Tsbt Presets - Resets the amplifier to factory default settings or user saved presets.

Application Settings - This is where communication between the amplifier and the PC is set up. You can also change the quality of the graphics or run a demo of the application - with simulated VU meter activity.

Reset Levels - This will reset all of the slider and rotary dial levels to -INF.

Calibration - This opens the calibration window, which provides a convenient way to calibrate the loop by generating a test tone (using the amplifier's internal tone generator), adjusting the frequency and output level, and measuring the signal level of the loop with a field-strength meter.

Note: The field strength meter can be purchased through Williams AV, model PLM FSMP. Please see our website or call us for more information.

Priority Input Selection - Allows selection of an input designated as an override to any/all inputs currently in use. When signal level appears on the priority input, all other outputs are muted until the signal on the priority input is not present for a period of time. This is useful for overhead paging/distributed speaker systems where announcements need to be heard by loop users.

Loop Test - Performs a test on the loop(s) looking for an open or faulty loop.

Amplifier Reset - This resets all settings to factory defaults and re-boots the amplifier.

Full-Screen View - This returns the App to a full-screen view if the window has been re-sized or moved.

Network Info - This shows the Ethernet Network Address settings and Dante™ Network Address settings.

System Info - This shows the currently loaded firmware versions of: main CPU, DSP chipsets, network driver and bootloader. It also displays the current PC App version.

PC APP MAIN SCREEN

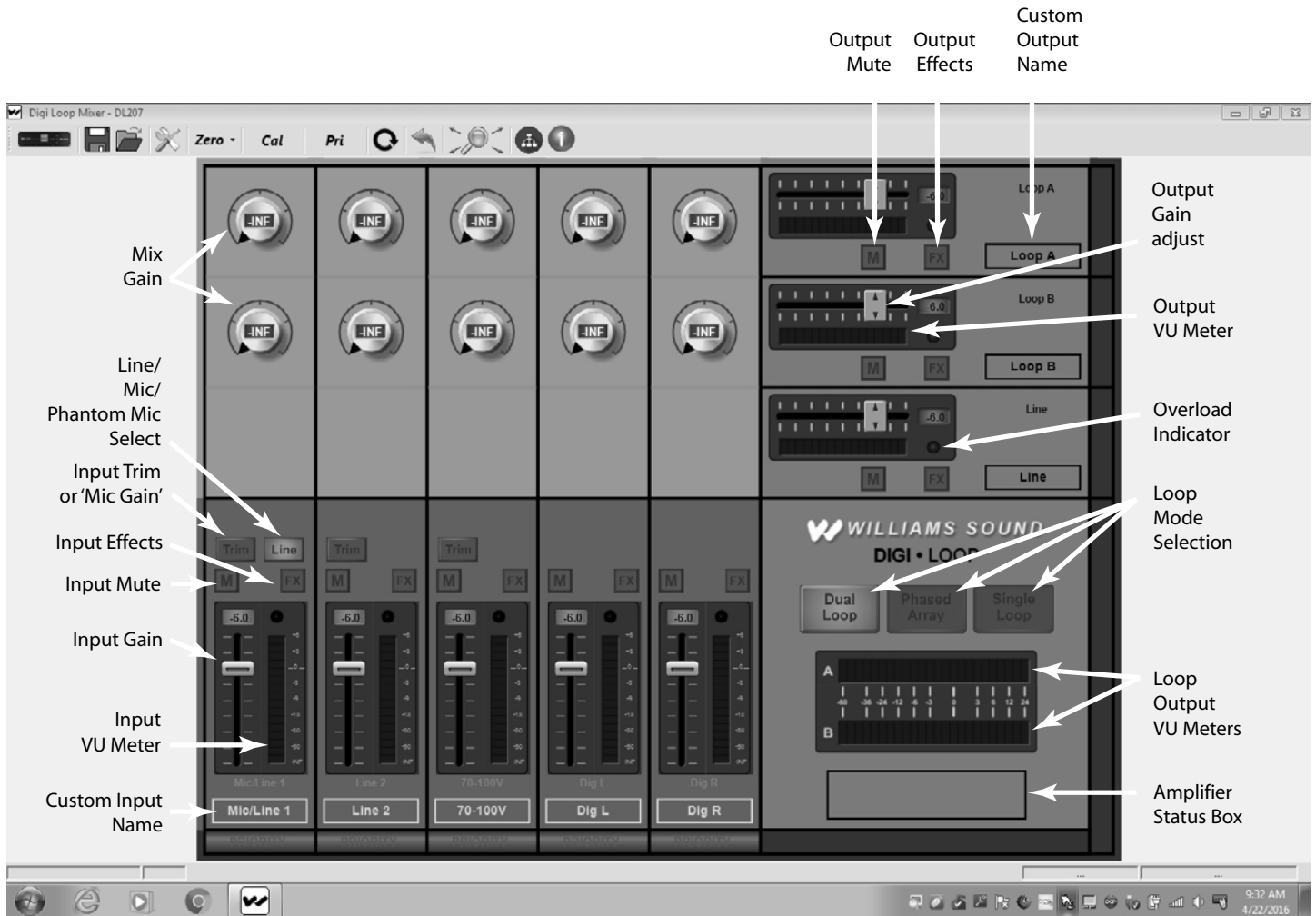

Mix Gain - Allows an additional point of control to mix individual inputs as required for each output. (Click on the dial, then slide up/down to adjust)

Line/Mic/Phantom Mic Select - Switches between a Line-level signal, dynamic microphone or 48 V condenser microphone.*

Input Trim - Provides fine trim of the input gain. **Caution! It is very important to make sure the appropriate input configuration is set BEFORE plugging the source into the Input 1 or Input 2 jacks.**

Digital In Switch - Switches “Digital In L” and “Digital In R” (inputs follow each other) to either Dante or AES/EBU.

Input Effects/Output Effects - Opens the Input or Output Effects adjustment window.

Input/Output Mute - Mutes the Input or Output without the need to use the slider control. Unmute returns to slider gain level.

Input VU Meter/Output VU Meter/Loop Output VU Meters - Shows the active level of the audio post-adjustment.

Input/Output Gain - Gain adjustment slider control.

Custom Input/Output Name - Provides the ability for a custom name. The jack label is preserved above the custom name.

Loop Modes - Changes the internal configuration of the amplifier to drive the load(s) chosen.

Input/Output Overload Indicators - This light will turn red once an overload condition is reached. It remains red until cleared. Clear the overload indicator by clicking on it.

Status Message Area - If the amplifier encounters error conditions, a specific message will be displayed in this area, i.e. if a loop is open.

INPUT EFFECTS WINDOW

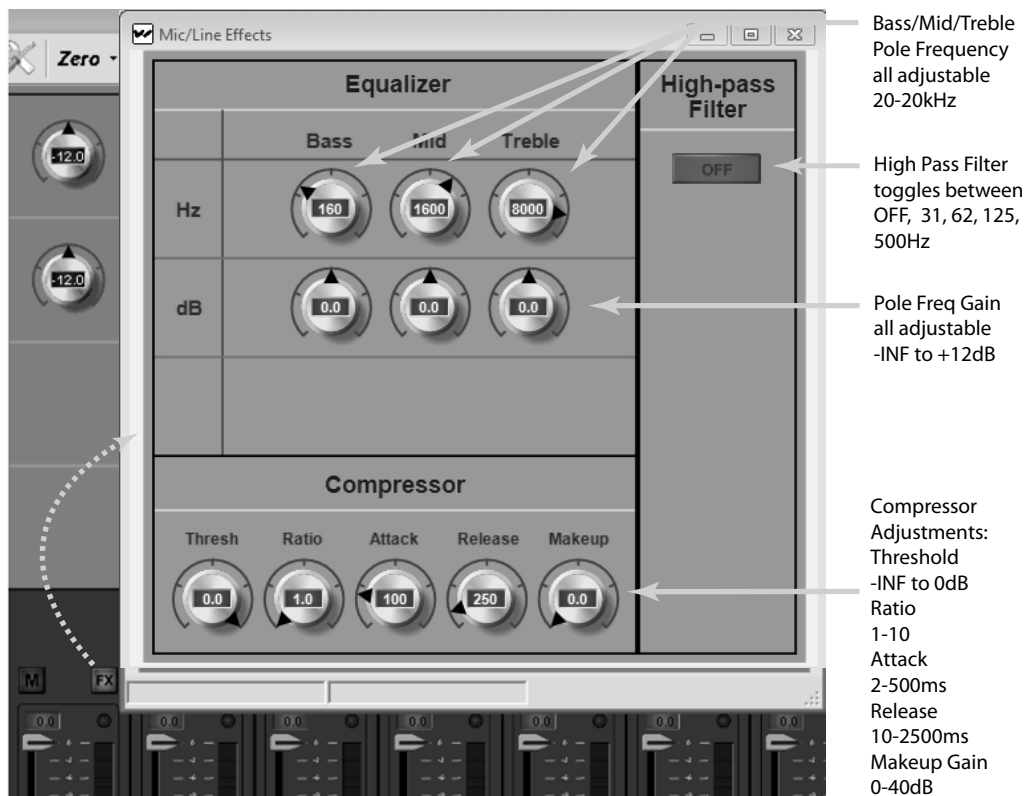

Equalizer

Hz (Bass/Mid/Treble Pole Freq) - Sets the center frequency for the gain adjustment of each band. (Click then slide up/down to adjust)

dB (Bass/Mid/Treble Pole Freq Gain Adjust)- Adjusts the amount of gain at the pole frequency. This is adjustable from -96.0 dB to 0.0 dB in 0.5 dB steps.

High Pass Filter

Each push of the button toggles between "OFF", 31 Hz, 62 Hz, 125 Hz, 500 Hz, and back to OFF.

Compressor

Threshold is the level of incoming signal at which compression takes effect. The Threshold is adjustable from -96.0 dB to 0.0 dB in 0.5 dB steps.

Ratio determines how much compression is applied when it takes effect. The Ratio is adjustable from 1.0:1 (no compression) to 10.0:1 in 0.1 steps.

Attack is the speed at which compression reacts to get to the target level. The Attack is adjustable from 2 ms to 500 ms in 2 ms steps.

Release controls the time that the compressor continues to work after the input signal drops beneath the threshold. Short settings release the signal quickly, while long release times have the effect of sustaining the signal. The Release is adjustable from 10 ms to 2500ms in 10ms steps.

Makeup Gain is used to bring the overall level of the sound back up, when the overall volume has been reduced by compression. This happens when the threshold is set low and/or the ratio has been set high. The Makeup Gain is adjustable from 0 dB to 40 dB in 0.5 db steps.

OUTPUT EFFECTS WINDOW

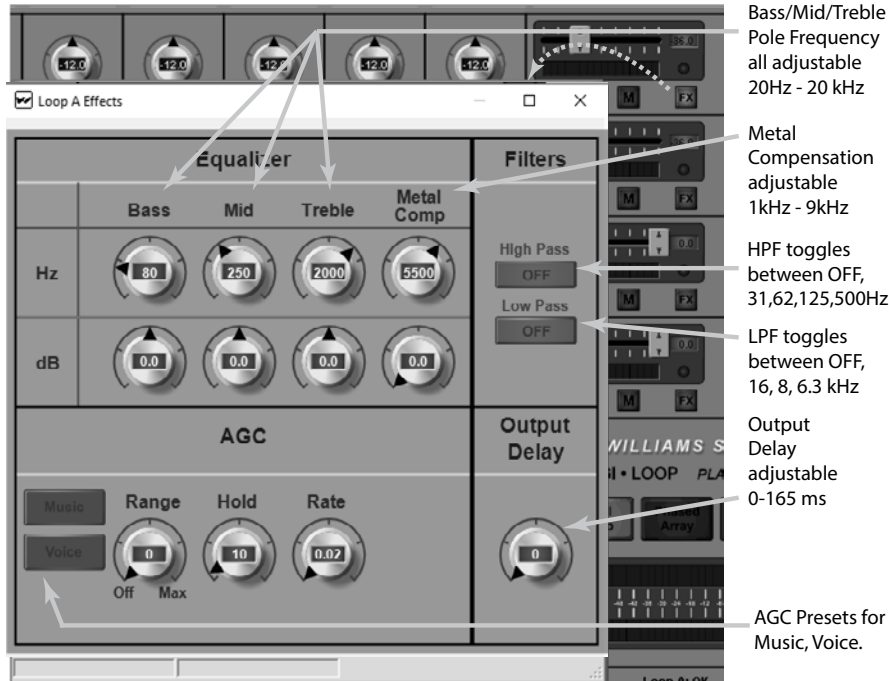

Output effects can be accessed from two different places - The “FX” button in the calibration window, or the “FX” button near the output slider.

Equalizer

Hz (Bass/Mid/Treble Pole Freq) - Sets the center frequency for the gain adjustment of each band.

dB (Pole Freq Gain Adjust) - Adjusts the amount of gain at the pole frequency chosen.

Metal Compensation - Additional parametric gain control to help overcome high-frequency loss caused by metal absorbing energy from the loop.

AGC (Automatic Gain Control)

Once the amplifier has been calibrated for the loop(s), the AGC (when active) will try to maintain that average level of signal to the loop(s) or speaker. For people familiar with traditional AGC, this level is known as the “Target”. There is no target adjustment on the loop amplifier since *the target is internally set by calibration.*

Presets: Music, Voice, and Custom The presets for *Music* and *Voice* are optimized settings for AGC. If more control is desired over the AGC parameters, or a third scenario is required, a *Custom Preset* can be created and recalled.

Level This dial applies active gain correction up to ± 20 dB around the target (the Level “window”). As the dial is turned up, more correction is applied. If the audio level is *below* the target, up to +20 dB (gain) is applied; *above* the target, up to -20 dB (attenuation) is applied.

Hold Time is how long AGC remains at the same level when the input signal drops out of the Level Window. The Hold Time adjustable from 1 second to 60 seconds in 1 second steps. For *Voice*, longer hold times are often used to maintain the gain level when the speaker pauses or stops talking. For *Music*, shorter hold times are often used since the signal tends to be continuously present.

Attack is the speed at which the gain is boosted when the level of the input signal crosses into the “Level” window. Short settings react to the signal quickly, while long attack times have a lagging effect. When the speaker pauses, too short of an attack can result in “pumping” or “breathing” where the sound gets really loud before returning the desired level.

Release is the speed at which the gain is reduced after the input signal drops out of the “Level” window. Short settings drop the gain quickly, while long release times have the effect of sustaining the signal. Too short of a release can result in missed parts of speech due to the gain dropping off too fast. Too long of a release can result in speech getting muddled or “ringing”.

Output Delay adjusts the timing of the audio at the output. This is useful when audio needs to match video (lip sync), or when amps are chained together in a deep venue where loop timing needs to coincide with delayed speaker arrays.

High Pass Filter - Each push of the button toggles between “OFF”, 31 Hz, 62 Hz, 125 Hz, 500 Hz, and back to OFF. Only use 500 Hz for a speaker.

Low Pass Filter - Each push of the button toggles between “OFF”, 16 kHz, 8 kHz, 6.3 kHz and back to OFF.

Output Delay - can be adjusted from 0 to 165 ms.

AMPLIFIER STATUS BOX AND STATUS WINDOW

The status box shows loop status at a glance. For more detail, open the Amplifier Status Window by clicking on the box.

Amplifier Status Window

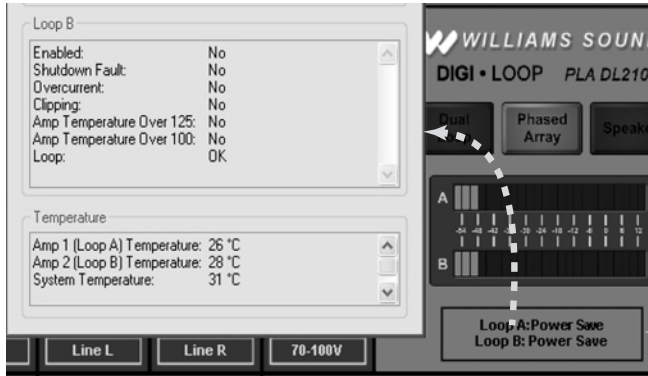

Status Box. Click inside the box to open the Amplifier Status Window.

CALIBRATION WINDOW

The amplifier must be calibrated to the loop(s) before the VU meters will be accurate. The loop system can then be adjusted to meet the frequency response requirements as per IEC 60118-4. For the complete procedure on calibrating the amplifier, please refer to the section “Setup and Calibration Procedure (using a laptop or windows tablet)”. When calibrating a Phased Array, after Loop A has been calibrated with the field strength meter, switch to Loop B, and adjust the Offset for Loop B until the Average Current for Loop B matches the average current for Loop A. Then individual test frequencies can be adjusted (i.e. 500 Hz, 1 kHz, 2.5 kHz, etc.) to make the frequency response of the loop meet IEC 60118-4.

Calibration Window (Phased-Array Mode shown)

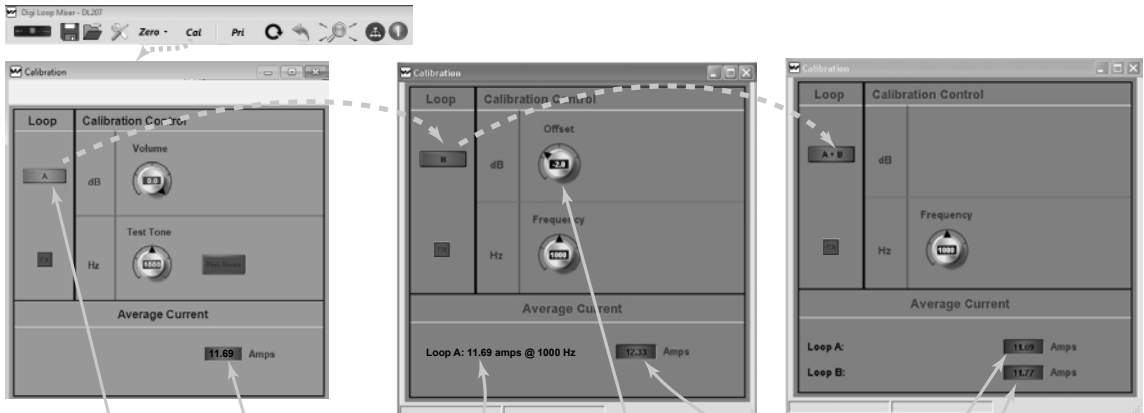

1. Click on this button to switch from Loop A to Loop B

Note: Average current delivered to Loop A.

2. Using the current in Loop A as a reference, adjust the offset for the current in Loop B until Loop B is close to Loop A.

When finished, the current for Loop A should be close to the current for Loop B.

1. Set the test tone at the first frequency to be measured (i.e. 500 Hz).
2. Click on the FX button to bring up the Output EQ

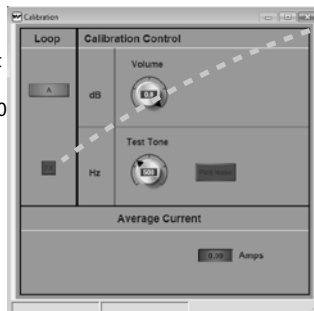

3. Set the same frequency as the test tone (i.e. 500 Hz) under the closest filter that applies (i.e. “Bass”).
4. Using the field strength meter, adjust the level until the FSM reads 0dB (400 mA/m).

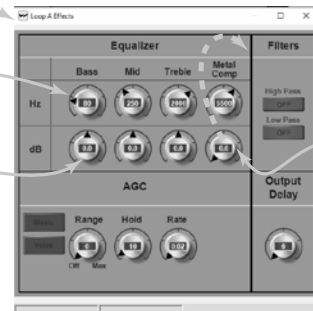

To enter a value, double-click on the value in the dial.

5. Close the FX window (return to step 1), set the next test tone, and return to the FX window to adjust the next frequency. Repeat these steps until the last frequency has been adjusted (i.e. 5 kHz).

Front LCD Menu

This is a full map of the front menu. Use the numbers next to each box to look up the function in the “Front Screen Menu Tree Detail” section, e.g. “7a1” - “Load Preset”.

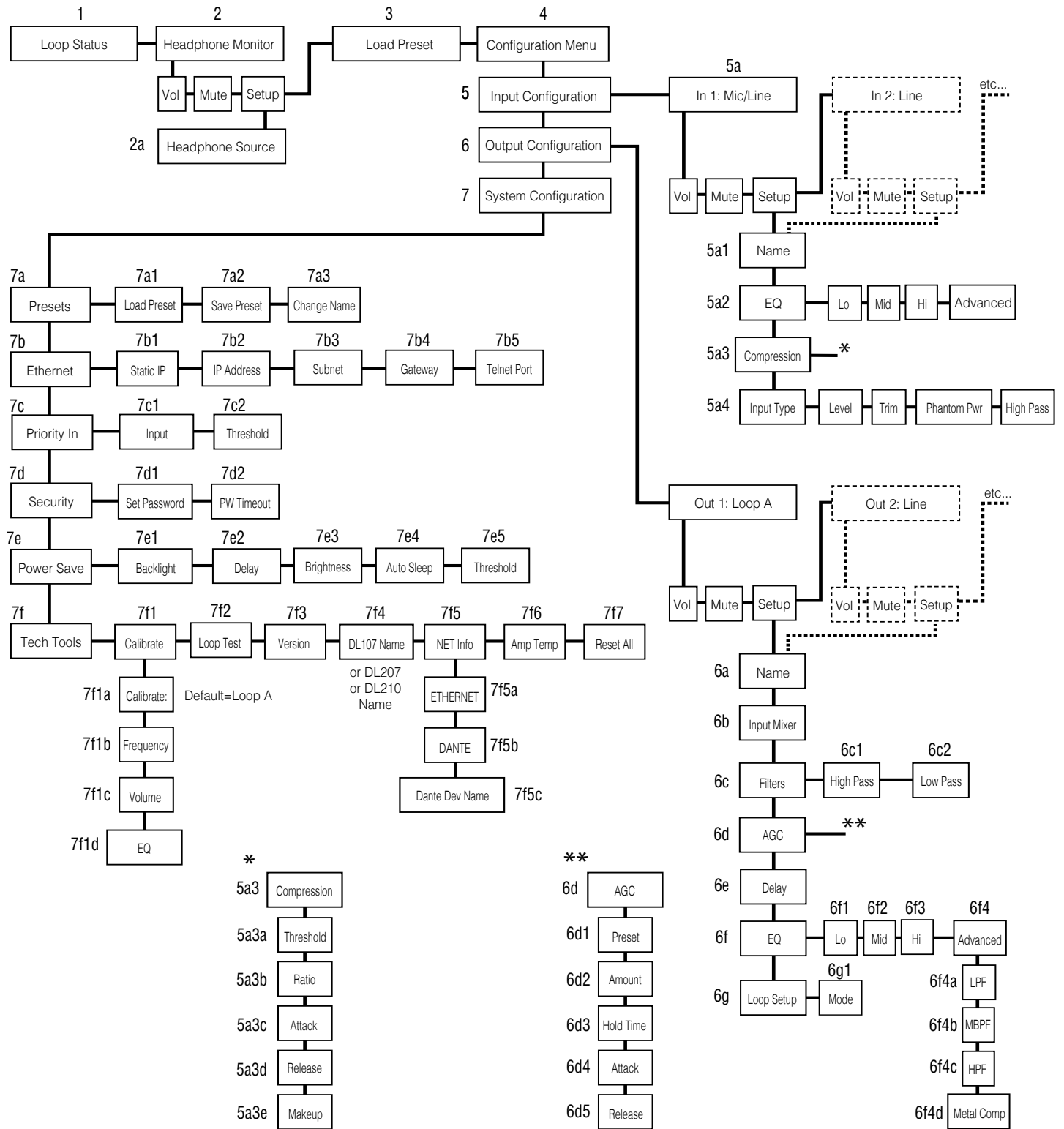

All aspects of the loop amplifier can be configured from the front panel GUI.

The on-board menus are navigated and adjusted using a rotary encoder labeled “ADJUST” and by pushing the knob in to “ENTER”.

There are a number of common operations:

To move to the next menu, turn the control clockwise. It might be necessary to cycle through the on-screen options until you get there. Clockwise moves forward; counter-clockwise moves back.

Pressing the control knob in (“ENTER”) moves the selection into that menu or option for further adjustment or options.

To change values: ENTER - ADJUST - ENTER (no escape or undo).

In order to exit a menu or option, select the “BACK” command in the list.

The screen will return to the “Loop Status” menu after a period of time.

Front Panel Controls

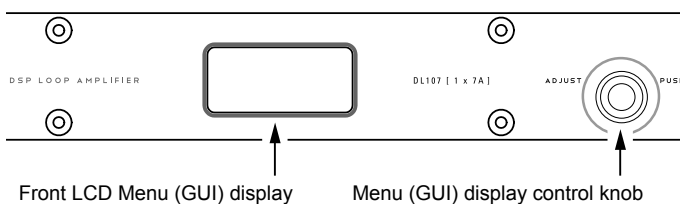

Front Screen Menu Tree Detail

The entire on-screen menu is accessed by either rotating the control knob to the left or right (to view), or pushing it in (to select).

See the Menu Tree (previous page) for an overview of the entire menu structure.

1. LOOP STATUS

The On-Screen Menu starts, and when it times-out, will return to the “Loop Status” Screen (below). The bars represent the power output of the loop(s), and will pulse with the audio program being broadcasted on the loop (or speaker). The vertical lines going through the bars represent the reference level of 0 dB.

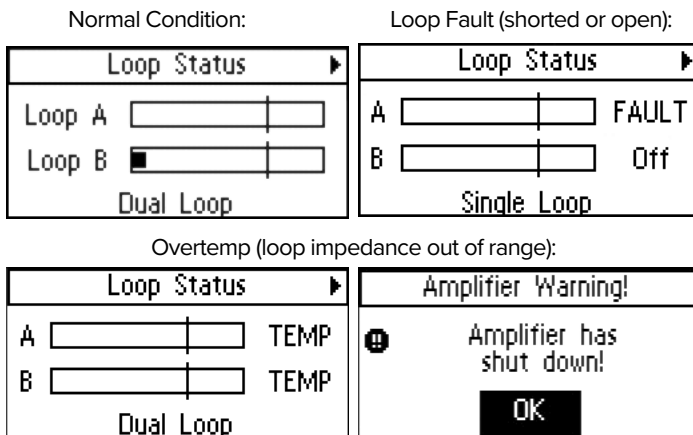

2. HEADPHONE MONITOR

The Headphone monitor can be used to listen to any individual source or output, or to listen to adjustments as they are made in the menu. Rotate the knob once to the right to see the Headphone Monitor screen. The vertical bar going through the bar graph represents a reference level of 0 dB. You can change the volume of the headphones or mute the audio from this screen.

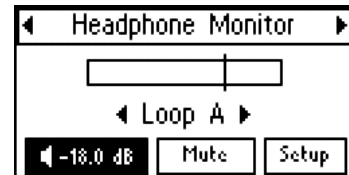

2a. Headphone Source

To change the headphone source, enter the Headphone Monitor Setup. Rotate the knob to view the sources. Push the knob in to select the source desired for the headphones.

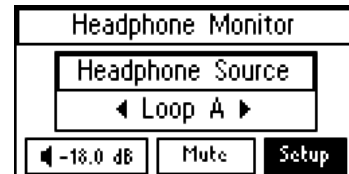

3. LOAD PRESET

Presets provide the ability to save and recall custom configurations (all amplifier settings). This is where a preset can be recalled, or “loaded”. To save a Preset, see 7a2.

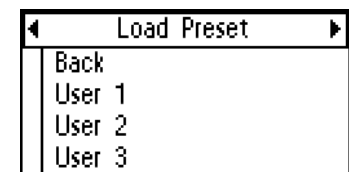

4. CONFIGURATION MENU

The configuration menu is where most of the amplifier settings and fine-tuning is performed. This menu is where Inputs and Outputs are configured and system parameters are set up, stored and recalled.

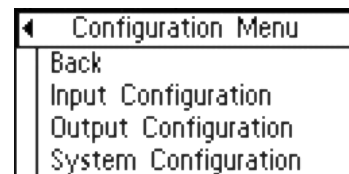

5. INPUT CONFIGURATION

The “Input Configuration” page allows the user to individually select and process the incoming signal for all inputs. It does not route the signal to the outputs. That task is carried out in the “Output Configuration” page under the “Input Mixer”.

From the Home Page (“Loop Status”), turn the ADJUST rotary control clockwise to navigate through the “Headphone Monitor” and “Load Preset” menus, to the “Configuration Menu”. Press ENTER and the selection moves into the Configuration Menu options. ADJUST rotary control clockwise to “Input Configuration” and press ENTER. Each input is separately adjustable and Input 1 is already selected.

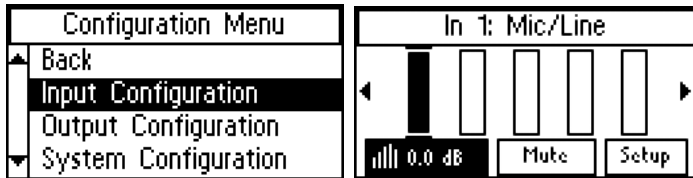

This menu shows an input meter for each of the seven inputs and has three options for the selected input along the bottom:

Gain - press and adjust

Mute - press to toggle

Setup - press to enter sub-menu. The available options for each input are: Name, EQ, Compression, Input Type

5a1. Name

This allows you to name the Input. To change the name, select the first character and rotate the dial to change letters/numbers. When the character you want is displayed, push the knob in to select that character and move to the next position. When finished with the last character of the name, rotate knob until “OK” is highlighted; then push the knob in to save the name.

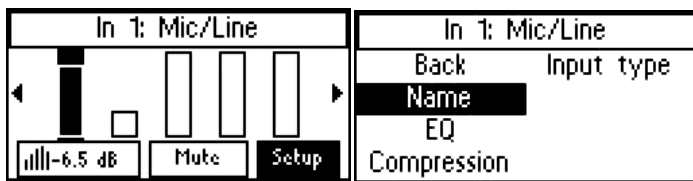

5a2. EQ

Frequency compensation is available via a 3-band equalizer: Lo Shelf - Mid Sweep - Hi Shelf. The center (or “cutoff frequency”) for each band is chosen under “Advanced Settings”. The second screen below shows the level adjustment for each of the bands (low range highlighted). Rotate the knob until “Advanced Settings” is highlighted and push the knob in to select. The 3rd screen below shows the advanced settings, where the center or cutoff frequency for each of the bands is chosen, as well as slope (in dB) for the cutoff.

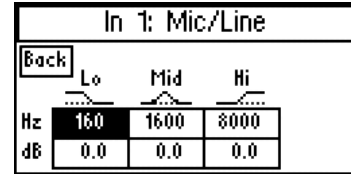
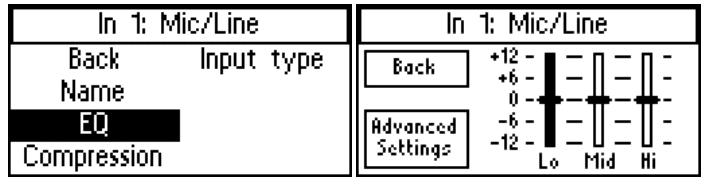

5a3. Compression

Compression reduces the dynamic range of the input/output, making soft sounds louder and loud sounds quieter. It has the overall effect of “volume levelling” so the entire program is more intelligible to the listener. Compression has 5 adjustable parameters: Threshold, Ratio, Attack, Release, and Makeup Gain.

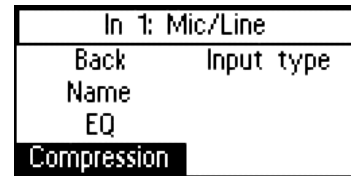

5a3a-d. Threshold, Ratio, Attack, Release, Makeup

Threshold is the level of incoming signal at which compression takes effect. The Threshold is adjustable from -96.0 dB to 0.0 dB in 0.5dB steps.

Ratio determines how much compression is applied when it takes effect. The Ratio is adjustable from 1.0:1 (no compression) to 10.0:1 in 0.1 steps.

Attack is the speed at which compression reacts when the input signal crosses the threshold. The Attack is adjustable from -0ms to 500ms in 2ms steps.

Release controls the time that the compressor continues to work after the input signal drops beneath the threshold. Short settings release the signal quickly, while long release times have the effect of sustaining the signal. The Release is adjustable from 0ms to 2500ms in 10ms steps.

Makeup Gain is used to bring the overall level of the sound back up, when the overall volume has been reduced by compression. This happens when the threshold is set low and/or the ratio has been set high. The Makeup Gain is adjustable from 0 dB to 40 dB in 0.5db steps.

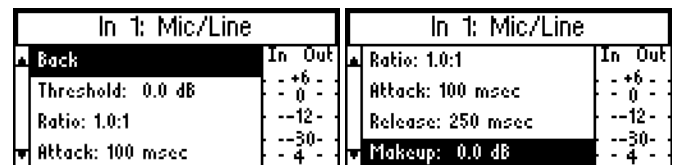

5a4. Input Type

The options for input type vary with the input being set-up. The options are in the table below.

Input & Type	Options
1 & 2 Dante	Hi-pass filter: <ul style="list-style-type: none"> • none • 31 Hz • 62 Hz • 125 Hz • 500 Hz
3 & 4 Analog Mic/Line	Level: <ul style="list-style-type: none"> • -10 dBU • +8 dBU • +4 dBU • Mic Trim Control: <ul style="list-style-type: none"> • 12 to 39 dB Phantom Power switch (only active when Mic type selected): <p>48v Phantom power is automatically turned on when "Microphone" is selected. Before using the microphone, check the owner's manual specifications about the use of phantom power.</p>
5 & 6 Unbalanced Line	Level: <ul style="list-style-type: none"> • -10 dBU • -4 dBU High-Pass Filter: <ul style="list-style-type: none"> • none • 31 Hz • 62 Hz • 125 Hz • 500 Hz

Input & Type	Options
7 70/100 V	Level: <ul style="list-style-type: none"> • 25 Vrms • 70 Vrms • 100 Vrms Hi-pass filter: <ul style="list-style-type: none"> • none • 31 Hz • 62 Hz • 125 Hz • 500 Hz

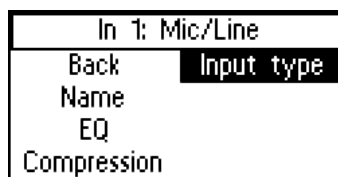

For example, if setting up the Mic/Line inputs, the 3-pin Phoenix (or XLR) Connector can be programmed to accept various levels: Line +4dBu, Line +8dBu, Line -10 dBV, or Microphone.

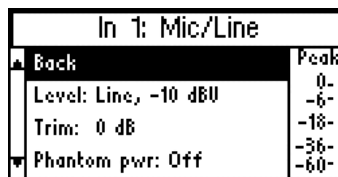

Phantom power is automatically turned on when "Microphone" is selected. Before using a microphone, check the owner's manual specifications about the use of phantom power.

The "Dig In L (or R)" input adjustments consist of a High Pass Filter Crossover Point (frequency) and Attenuation (dB).

Note: The "Dig In L" and "Dig In R" inputs are independent, and can be "mixed" in the PC App to be routed to separate loops. These inputs can be switched here, or in the PC App (see the section "Using the PC Application" - "PC App Main Screen" - "Digital Input Switch").

5a4a-d. Level, Trim, Phantom Power, High Pass

Level sets the incoming signal level as it applies to the device being used. There are five possible level settings: Microphone, Line -10 dBU, Line -4 dBU, Line +4 dBU, and Line +8 dBU.

Trim or Gain This setting is dependent on input level and type chosen.

When a *Line Level* is selected (above), this setting allows *Trim* to be adjusted. Trim is adjustable in 3 dB increments from -6 dB to +57 dB.

When *Microphone Level* is selected (above) this setting allows *Gain* to be adjusted. Gain is adjustable in 3 dB increments from +9 dB to +63 dB.

Phantom Power is available as a setting if Microphone Level was

chosen (above). Phantom power can be turned ON or OFF. When ON it provides a supply voltage of 48v to the microphone.

High Pass is a high-pass filter with selectable crossover points. The crossover point can be set to: Off, 31 Hz, 62 Hz, 125 Hz or 500 Hz.

6. OUTPUT CONFIGURATION

The “Output Configuration” menu controls the signal passing to loops (and/or loudspeaker when using the DL210), as well as the line outputs. The loop outputs have comprehensive control, while the line level outputs have the ability to change the name and apply EQ.

Each of the outputs can be configured individually. To set up Output 1, enter “Output Configuration”. Output 1 is the first input you can adjust, so it is already selected. To get to the next input, rotate the knob to the right.

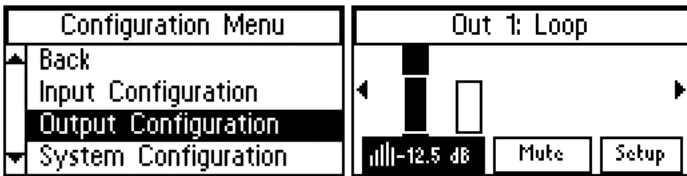

6a. Name

This allows you to name the Output. To change the name, select the first character and rotate the dial to change letters/numbers. When the character you want is displayed, push the knob in to select that character and move to the next position. When finished with the last character of the name, rotate knob until “OK” is highlighted; then push the knob in to save the name.

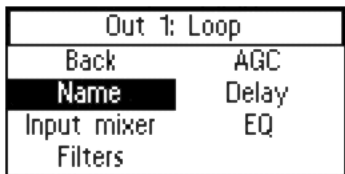

6b. Input Mixer

The Input Mixer provides level adjustment of each of the inputs per each output. This is used when one (or more) input(s) may be louder or softer than the others. You can use the headphones plugged into the headphone jack to monitor the adjustments.

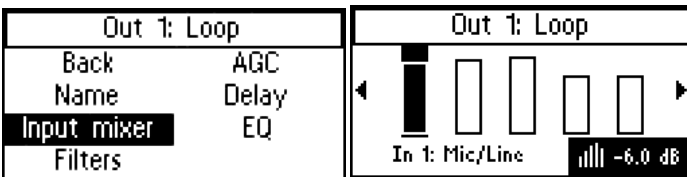

6c. Filters

Filters provide adjustment for a high pass filter and low pass filter crossover frequency.

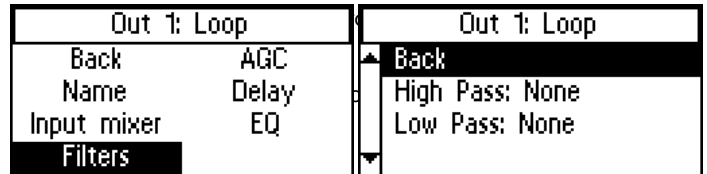

6d. AGC

Automatic Gain Control measures the average level of the signal and applies gain reactively to keep the output level constant. It also limits the output power and reduces or eliminates distortion due to clipping that would normally occur without AGC.

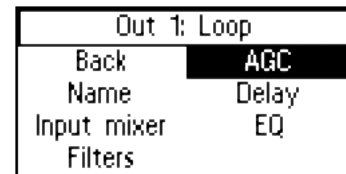

6d1-6. AGC Level, Hold Time, Attack, Release

Preset provides default settings for Voice and Music, and only the Amount is adjustable. A Custom preset allows adjustment of the Hold Time, Attack, and Release. Voice is designed for pauses in the audio, where Music is designed for more constant-level sources.

Amount of the AGC can be adjusted to a maximum of 20 dB of around the calibrated level, or “target” level. For people familiar with traditional AGC, the Target is internally set to the calibrated level and is not adjustable, and the Minimum Level (also called “Threshold”) is internally set relative to the calibration target level and is not adjustable. The calibrated “target” level is set in Tech Tools-Calibrate, and this is the level the AGC will attempt to hold.

Hold Time is how long the gain is maintained on signal when the automatic gain settings take effect. In the Custom preset, the Hold Time is adjustable from 1 second to 60 seconds in 1 second steps.

Attack is the speed at which the AGC reacts when the level of the input signal crosses the threshold. Short settings react to the signal quickly, while long attack times have a lagging effect. In the Custom preset, the Attack time is adjustable from 0.5 s to 3.5 s in 0.5 s steps.

Release is the amount of time that the AGC continues to work after the input signal drops beneath the threshold. Short settings release the signal quickly, while long release times have the effect of sustaining the signal. In the Custom preset, the Release time is adjustable from 0.5 s to 3.5 s in 0.5 s steps.



6e. Delay

Delay is the amount of time between the input signal and the output signal of the amplifier. This is often useful in a loop system when a PA system is also being used, so that the audio being heard through the loop (receiver or hearing aid) matches that of the PA System speakers. Delay helps to eliminate this “echo” effect. The Delay is adjustable from 0 ms to 165 ms in 1 ms steps.

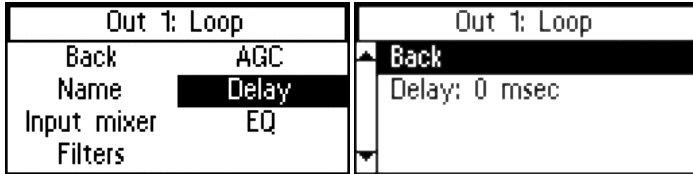

6f1-3. EQ - Lo, Mid, Hi

The EQ is a Parametric Equalizer. In the basic settings (second screen, below), there is a low, mid-band, and high frequency slider that can be adjusted between -12 dB and 12 dB. To review or change the pole frequencies, see “6f4a-d. Advanced Settings”, below.

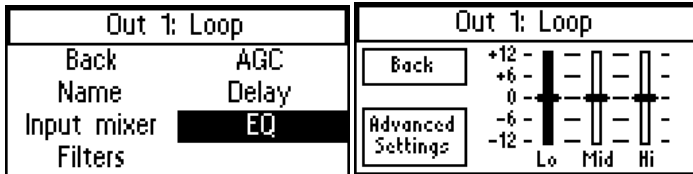

6f4a-d. Advanced Settings - Lo, Mid, Hi, Metal Comp

Advanced Settings provide the ability to change the frequency point, define a more specific numerical dB level, or adjust for high-frequency metal loss. The Lo, Mid, and Hi filters can all be adjusted from 20 Hz to 20kHz, and -12 dB to +12 dB. The Metal Compensation can be adjusted from 1 kHz to 9kHz, and -12dB to +12 dB.

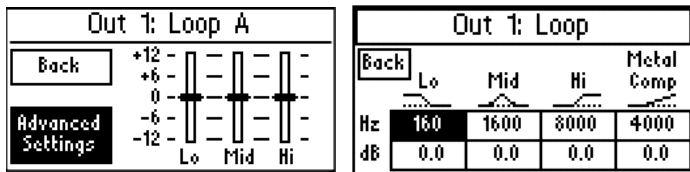

6g. Loop Mode (model DL207/210 only)

- *Loop Mode* configures the outputs for different loop/speaker combinations. Use *Dual-Loop mode* to drive a single loop or two single loops (not overlaid, no phase shift).
- Use *Phased Array mode* for two overlaid loops in a phased array layout (where 90° phase-shifting is needed).
- Use *Speaker mode* if output A will be used to drive a speaker, and output B will drive a loop or be left open.

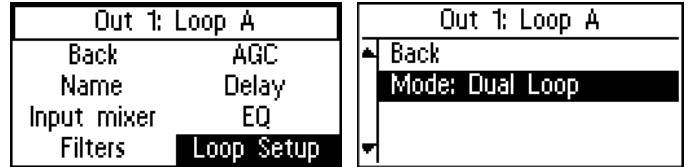

7. SYSTEM CONFIGURATION

7a1-3. Presets - Load Preset, Save Preset, Change Name

Presets allow the user to store all of the current amplifier settings into one easy-to-access Preset, and recall the Preset when needed. These presets are stored in the amplifier (not to be confused with saving or loading a configuration file, which can only be done through the PC App and is stored on a computer). Three presets are available as a starting point, with defaults, as shown - Dual-Loop, Phased-Array, and Speaker/Loop. There are also three Custom Presets available - User 1, User 2, and User 3. The User Presets can be renamed. The Dual-Loop, Phased Array and Speaker/Loop Presets cannot be altered or saved; they can only be loaded.

We recommend saving the settings in a User Preset in case of power outage or other catastrophic failure. Settings should be saved immediately after the system is calibrated.

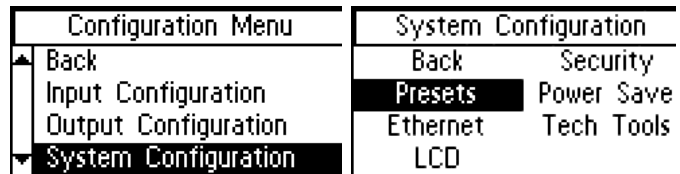

7b1-5. Ethernet

Ethernet provides the ability to specify a static IP Address for the amplifier, or choose dynamic IP addressing (DHCP).

If using DHCP, you must go to a different screen in the menu to view the router-assigned IP Address is (See “Tech Tools - Net Info”). The DHCP address is not displayed here.

The amplifier must be set up with an IP Address through the front LCD screen before a networked (or direct-connected) PC can communicate with it. The PC/iPad App won't work until those settings are made. If using DHCP, the address needs to be verified through the “Tech Tools-Net Info” screen so this address can be entered into the App, before it will communicate with the amplifier. In order to use the PC/iPad App, the amplifier must be in the same IP Address range, and subnet, as the PC/iPad.

The telnet port defaults to 23 and should not be changed.

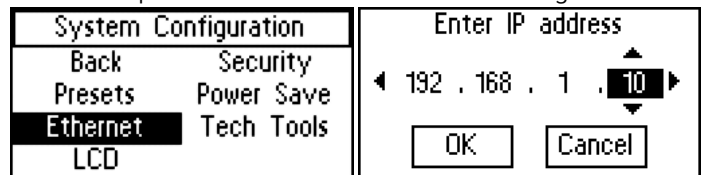

Important! If changing from DHCP to a static IP Address, the amplifier must be powered Off, then On, for the new static IP address to take effect!

7c1-2. Priority In

A priority input overrides the current input in use when signal appears on the priority input. The priority input can be assigned in the LCD menu.

This feature is useful for overhead announcements or paging events.

System Configuration		System Configuration	
Back	Security	Back	
Presets	Power Save	Input: ◀ 70-100V ▶	
Ethernet	Tech Tools	Threshold: -40 dB	
Priority In			

7d1-2. Security - Set Password, Password Timeout

The Security function allows you to set a password and determine the password timeout delay. The 3-digit access password restricts unauthorized configuration changes. The password cannot be recalled or displayed on the screen. The password timeout delay determines how long the amplifier will display the password entry screen.

The password can be reset by starting with the unit off, pushing the knob in and holding it, turning on the amplifier (while continuing to hold the knob in), and waiting until the screen shows “System Password Cleared” (roughly 20 seconds). A reset to factory defaults will also reset the password, but it will also erase all stored presets and system settings.

System Configuration		System Configuration	
Back	Security	Back	
Presets	Power Save	Set configuration PW	
Ethernet	Tech Tools	PW timeout: 5 min	
LCD			

7e1-2. Power Save - Backlight, Delay, Brightness, Auto-Sleep, Threshold

The power save function will turn the amplifier off after a period (Auto Sleep Delay) when the input audio level falls below a specified level (Threshold).

Backlight can be turned On or Off.

Backlight Delay is adjustable in 10 second increments from 10-60 seconds.

Brightness has 10 levels, from 1-10.

Auto Sleep delay is adjustable in 10 minute increments from 10-120 minutes. Default setting is 30 minutes.

Threshold is adjustable from -80 dB to -30 dB in 1 dB steps. Default setting is -80 dB.

System Configuration		System Configuration	
Back	Security	Back	
Presets	Power Save	Backlight: On	
Ethernet	Tech Tools	Delay: 30 sec	
LCD		Brightness: 10	

7f. Tech Tools

Tech Tools provides the ability to calibrate the amplifier through use of a test tone, perform an open loop test, check the firmware version(s) of the ICs, name the amplifier, set a static or dynamic IP address, and reset the amplifier to factory default settings.

System Configuration	
Back	Security
Presets	Power Save
Ethernet	Tech Tools
LCD	

7f1a-d. Calibrate - Calibrate, Frequency, Volume, EQ

This is the tool used to calibrate the amplifier to the loop(s). The goal during calibration is for the loop’s performance to meet IEC Specification 60118-4.

System Configuration	
Back	DL107 Name
Calibrate	NET Info
Loop Test	Amp Temp
Version	Reset All

Calibrate determines which output (Loop A or Loop B) to send the test tone to. If calibrating a phased array, loop A will be done first, and loop B second.

Frequency of the test tone can be set to 100 Hz, 500 Hz, 1 kHz, 2.5 kHz, 5 kHz, or Pink Noise. These test tones are used to calibrate the amplifier with the use of a field strength meter. If the levels at different frequencies need to be adjusted, the Output EQ (see below) can be used to raise or lower the output level at that frequency. On the DL210 2.0, when the amplifier is set to Loop + Speaker mode, Pink Noise can be used to evaluate the speaker response with the entire frequency range driven.

System Configuration		System Configuration	
Back	Amps	Back	Amps
Calibrate: Loop A	0.1	Calibrate: Loop A	0.0
Frequency: 1 kHz	15-	Frequency: ◀ Pink Noise ▶	15-
Volume: -40 dB	10-	Volume: 0 dB	10-
	5-		5-
	0-		0-

Volume of the test tone can be adjusted from -96 dB to 0 dB in 1 dB steps. Once the loop’s response is adjusted to be nearly flat, volume can be used to adjust the field strength to meet the 400 mA/m (per IEC 60118-4) at the measurement point.

EQ is used to during calibration to adjust the loop output level at the test frequencies until the loop output at each frequency measures 400mA/m on the field strength meter. It is a 4-pole parametric equalizer, with a low-pass, band-pass, high-pass and metal comp filters. For example, when calibrating to 500 Hz, the Low Pass setting would be adjusted to 500 Hz, and the level (dB) adjusted until the output of the loop is 400mA/m on the field strength meter. Then this process is repeated for the next frequency (i.e. 1 kHz, 2.5 kHz, 5 kHz). The Metal Comp filter allows additional gain to be added if there is metal loss, as metal loss tends to affect the higher frequencies in a loop system.

System Configuration				
Back	Lo	Mid	Hi	Metal Comp
Hz	160	1600	8000	4000
dB	0.0	0.0	0.0	0.0

System Configuration				
Back	Lo	Mid	Hi	Metal Comp
Hz	500	1000	2500	5000
dB	-0.5	0.0	+2.5	+4.0

7f2. Loop Test

The Loop Test function performs a test algorithm to verify that the load falls within the acceptable range of 0.5 Ω to 3.0 Ω. If the load is outside this range (essentially open or shorted) the test will show “FAULT”.

Note that when running a single loop in dual-loop mode, a “FAULT” is acceptable for the output with no loop connected. However, in this case, the unused loop output should be turned off in the menu.

This tool is to verify that a connected loop does not have an open (break) in it.

System Configuration	
Back	DL107 Name
Calibrate	NET Info
Loop Test	Amp Temp
Version	Reset All

System Configuration	
Loop A:	Pass
	1.7 ohms
Loop B:	Pass
	1.7 ohms
Test	OK

7f3. Version

Version is an info screen that shows the firmware version of the bootloader chip, main processor chip (CPU), DSP chip#1, DSP chip #2 and the ethernet card firmware version.

System Configuration	
Back	DL107 Name
Calibrate	NET Info
Loop Test	Amp Temp
Version	Reset All

Firmware version info	
Boot:	1.01
CPU:	0.106
DSP1:	0.106
DSP2:	0.106
Network:	N-0.78
OK	

7f4. DL107/207/210 Name

The DL107/207/210 Name provides the ability to give the amplifier an 8-character name for easy identification when connecting to it through the PC App on a network. This name will show up on a drop-down list in the PC App as an available device to connect to. For example, if 5 amplifiers were connected on the network, and the third amp was designated for the Ballroom, you could connect to “Ballroom” amplifier to make changes to that amp’s settings.

System Configuration	
Back	DL107 Name
Calibrate	NET Info
Loop Test	Amp Temp
Version	Reset All

Enter DL107 Name	
◀	█
	▶
OK	Cancel

7f5. NET Info

This screen is for viewing Ethernet and Dante parameters of the amplifier. No changes can be made from this screen.

Four parameters can be viewed here: (1) Ethernet Address and MAC address of the ethernet card, (2) Ethernet Address and MAC address of the Dante card, (3) the Dante Card Name, and (4) the Default Dante Card Name. To set the ethernet parameters, see section “7c

Ethernet”. To set the DL107/207/210 Name, see the previous section “7g4 DL107/207/210 Name”. To set the Dante parameters, use *Dante Controller*. (For more information about installing/using Dante controller, please visit Audinate’s website: <https://www.audinate.com/products/software/dante-controller>).

System Configuration	
Back	DL107 Name
Calibrate	NET Info
Loop Test	Amp Temp
Version	Reset All

System Configuration	
Back	ETHERNET
	IP addr: 192.168.100.173
	Subnet: 255.0.0.0

System Configuration	
Back	DL107 Name
Calibrate	NET Info
Loop Test	Amp Temp
Version	Reset All

System Configuration	
Back	DANTE
	IP addr: 169.254.128.46
	Subnet: 255.255.0.0
	Gateway: 0.0.0.0
	Telnet Port: 23

7f6. Amp Temp

The temperature of the two amplifier output stages and the CODEC (audio processor chip) can be monitored here. A “zZ” by the temperature means that the amplifier is in sleep mode (see “7f. Power Save” for how to adjust when the amplifier goes to sleep).

System Configuration		Amplifier Temperature	
Back	DL107 Name	Amp 1:	45°
Calibrate	NET Info	Box Fan:	🌀
Loop Test	Amp Temp	Amp 2:	45°
Version	Reset All	Amp Fan:	🌀
		CODEC:	40°
		OK	

7f7. Reset All

This resets all of the settings back to factory defaults - except the Ethernet and Dante Network Settings. Any other user-entered information will be lost. The amplifier may need to be rebooted after the factory reset is performed to change states. For example, if the amplifier goes to sleep it may still be asleep until it gets rebooted.

Note: The PC App gives the user the ability to save all settings to a configuration file for recall later. In this manner, all settings can be erased (here) to bring the amplifier back to a known state (factory defaults) for troubleshooting purposes, etc. Then if desired, a saved configuration can be loaded back into the unit via the PC App. It is good practice to store backup configurations in a configuration file (see PC App section) if much work has been done to finely adjust the amplifier.

System Configuration		Reset All	
Back	DL107 Name	All settings have been reset to factory defaults	
Calibrate	NET Info	OK	
Loop Test	Amp Temp		
Version	Reset All		

Specifications

DL107 NET, DL107 NET D, DL207 NET, DL207 NET D

GENERAL

Dimensions	1 RU Rackmount, 19" W x 1.75" H x 10" D. Chassis is 17" W.
Weight	DL107: 9.2 lbs (4.2 kg) DL207: 9.2 lbs (4.2 kg)
Color	Case: Black, white and blue legends on front, white legends on back. LCD: Backlit Blue.
Fan cooling	Variable Speed, Temperature Controlled
Power supply	Internal, Universal 100-240 VAC, 50/60 Hz, 200 Watt. Fuse: 5 x 20 mm, 5 A, 250 V. AC power plug is IEC 320-C14.
Heat output @ 120 VAC	DL107 : Sleep State: 63 BTU/hr; Idle State: 71 BTU/hr; Driving one loop @ 9.5 A: 339 BTU/hr
	DL207 : Sleep State: 63 BTU/hr; Idle State: 84 BTU/hr; Driving two loops @ 9.5 A each: 638 BTU/hr
Ethernet	(1x) RJ-45; 10-100 MBps.
USB	(1x) standard-B. USB 1.1, 2.0 or 3.0 supported.
Environment	0-35° C (32-95° F), 0-90% relative humidity,
Coverage area*	DL207 (dual output amplifier): 30,000 sq. ft. (2,786 sq. m.) (Perimeter Loops, 3:1 aspect ratio, both outputs driven) 18,000 sq. ft. (1,672 sq. m.) (Perimeter Loops, 1:1 aspect ratio, both outputs driven)
	DL107 (single output amplifier): 15,000 sq. ft. (1,393 sq. m.) (Perimeter Loop, 3:1 aspect ratio) 9,000sq. ft. (836 sq. m.) (Perimeter Loop, 1:1 aspect ratio)

INPUTS

Dante input	On "D" models only. (1x) RJ-45;100 Mbps. Minimum latency: 2 ms. Audio sample rates supported: 44.1, 48 kHz. Resolution: 24 bits.
Line inputs	(1x) 3-position terminal block, 10 kΩ input impedance. Configurable/accepts -10 dBV, -4 dBu, +4 dBu, +8 dBu, balanced or unbalanced. Level adjustable 0 to -96 dB.
Mic/Line inputs	(1x) XLR 3-pin jack. Input impedance: 1.5 kΩ Mic, 10 kΩ Line. Configurable/Accepts: Mic, Line -10 dBV, Line +4 dBu, or Line +8 dBu, balanced or unbalanced. Phantom supply (24 V).
70-100 V input	(1x) 2-position terminal block; high/speaker-level input (accepts 25 V, 70 V or 100 V) from distributed audio/paging systems.

OUTPUTS

Line outputs	(1x) 3-position terminal block; loop-through of Mic/Line Input 1 & Line Input 2, +4 dBu, Balanced or Unbalanced. The line outputs mirror the audio of the loop output.
Loop output(s)	(1x) 2-position terminal block per output
Audio output delay	Adjustable from 0 to 165 msec
Headphone output	(1x) 1/4" stereo headphone jack, on front of unit. Monitored input or output selectable in menu.
Loop fault relay	(1x) 3-position terminal block providing NC, NO and Common. Contact rating: 2.0 A @ 30 VDC.
Loop output drive voltage	16.1 Vrms (22.8 Vpk) continuous
Rated loop output current*	9.5 Arms (13.4 Apk) per output
Loop resistance range	0.5 Ω to 3.0 Ω (DC)

AUDIO

Rated load*	0.5 Ω DC with 135 μH inductance
Frequency response	45 Hz to 9.0 kHz ± 2 dB (1 kHz ref.)
Rated loop THD*	<1% at rated output current (1 kHz sine wave).

DL210 NET and DL210 NET D

Dimensions	2 RU Rackmount, 19" W x 3.5" H x 12" D. Chassis is 17" W.
Weight	14.3 lbs (6.5 kg)
Color	Case: Black, white and blue legends on front, white legends on back. LCD: Backlit Blue.
Fan cooling	Variable Speed, Temperature Controlled
Power supply	Internal, Universal 100-240 VAC, 50/60 Hz, 250 Watt. Fuse: 5 x 20 mm, 5 A, 250 V. AC power plug is IEC 320-C14.
Heat output @ 120 VAC	Sleep state: 100 BTU/hr; Idle state: 146 BTU/hr; Driving two loops @ 12 A each: 1,040 BTU/hr
Ethernet	(1x) RJ-45; 10-100 MBps.
USB	(1x) standard-B. USB 11, 2.0 or 3.0 supported.
RS-232/Loop fault relay	(1x) DB-9 jack. RS-232: Pin 2=Tx, Pin 3=Rx, Pin 5=gnd. Loop fault relay: Pin 1=NC, Pin 4=Common, Pin 6=NO. Relay contact rating: 2.0 A @ 30 VDC.
Environment	0-35° C (32-95° F), 0-90% relative humidity.
Coverage area*	31,400 sq. ft. (2,917 sq. m.) (Perimeter Loop, 1:1 aspect ratio, both outputs driven) 51,660 sq. ft. (4,800 sq. m.) (Perimeter Loop, 3:1 aspect ratio, both outputs driven)

INPUTS

Dante input	DL210 NET D 2.0 model only. (1x) RJ-45;100 Mbps. Minimum latency: 2 ms. Audio sample rates supported: 44.1, 48 kHz. Resolution: 24 bits.
Mic/Line inputs	(2x) 3-position terminal block, input impedance=1.5 kΩ Mic, 10 kΩ Line. Configurable/Accepts: Mic, Line -10 dBV, Line +4 dBu, or Line +8 dBu, balanced or unbalanced. Phantom supply (48 V).
70-100 V input	(1x) 2-position terminal block; high/speaker-level input (accepts 25 V, 70 V or 100 V) from distributed audio/paging systems.

OUTPUTS

Line outputs	(1x) 3-position terminal block; loop-through of Mic/Line Input 1 & Line Input 2, +4 dBu, Balanced or Unbalanced. The line outputs mirror the audio of the loop output.
Loop output(s)	(1x) 2-position terminal block per output
Audio output delay	Adjustable from 0 to 165 msec
Headphone output	(1x) 1/4" stereo headphone jack, on front of unit. Monitored input or output selectable in menu.
Loop fault relay	Integrated into RS-232 DB-9 jack. Pin 1=NC, Pin 4=Common and Pin 6=NO. Contact rating: 2.0 A @ 30 VDC.
Loop output drive voltage	33.3 Vrms (47.1 Vpk) continuous
Rated loop output current*	12 Arms (17 Apk) per output
Loop resistance range	0.5 Ω to 3.0 Ω (DC)
Speaker output	Integrated into Loop Output A terminal block (switchable in menu). 225 Watts x 1 channel @ 4 Ω, 125 Watts x 1 channel @ 8 Ω, (Class D). Frequency response = 20 Hz - 20 kHz, THD=0.07%.

AUDIO

Rated load*	0.5 Ω DC with 135 μH inductance
Loop frequency response	45 Hz to 9.0 kHz ± 2 dB (1 kHz ref.)
Rated loop THD*	<1% at rated output current (1 kHz sine wave).

OTHER

Front controls	Front LCD display menu access/adjustment via control button/dial.
Adjustable settings	Input mixing, parametric equalization, compression, metal loss compensation, high and low-pass filters, AGC and audio delay, output levels. See User Manual for adjustment range(s).
Internal calibration tools	Test tone generator with pink noise, loop current adjustment/matching. See User Manual for details.
Other features	Save/load configuration, loop test, priority input selection with adjustable threshold, loop fault relay, open/short and thermal protection.
Network control & firmware	Function control and calibration by DigiLoop PC App via ethernet (RJ-45). PC App requires Windows 7 or higher. Firmware updates through USB only.
Warranty	5 years
Approvals	CE, UL, ULC, FCC, Industry Canada, RoHS, WEEE, CB scheme, RCM
Standards compliance	This product is designed to meet the IEC-60118-4 standard when correctly designed, installed and commissioned. Test Specifications provided to the IEC 62489-1 standard.

Resources

- **Manuals and Specifications** can be downloaded by visiting our website and clicking on Support - Document Library - Manuals (or Specifications). You may also find them by visiting the product page for the model you have, and clicking on the “Downloads” tab.

- **Firmware and Software** (such as the PC App) can be downloaded by visiting our website and clicking on Support - Software, or by visiting the product page for the model you have, and clicking on the “Downloads” tab.

- A **Loop Certification Form** (final test checklist, filled out and signed by integrator and venue manager, certifying that the system is complete and conforms to IEC 60118-4) may be found by visiting our website and clicking on Support - Document Library - Supplements - “Induction Loop Certification Form (IEC 60118-4)”.

- **Loop System Designs** are provided at no charge to authorized dealers, distributors or integrators who have a specific projects with signed contracts. Once a design request form is received by our Tech Blue Department (available on our website), these designs are created.

- **Technical Support** is provided by our Tech Blue Department from 8:00 a.m. - 4:30 p.m. Central Time. You can reach us by calling 800.328.6190 (Ask for TechBlue) or send an email to techblue@williamsav.com.

Warranty

Williams Sound products, a brand owned by Williams AV, are engineered, designed, and manufactured under carefully controlled conditions to provide you with many years of reliable service.

Williams AV warrants the *DL107 NET, DL107 NET D, DL207 NET, DL207 NET D, DL210 NET 2.0, and DL210 NET D 2.0 Digi-Loop™ DSP Induction Loop Amplifiers* against defects in materials and workmanship under normal use and conditions for 5 years from date of purchase.

This warranty is available to the original end purchaser of the product and CAN BE transferred to subsequent purchasers of the product.

Microphones, earphones, headphones, batteries, chargers, cables, carry cases, and most other accessory products carry a 90-day warranty.

Williams AV has no control over the conditions under which this product is used. Williams AV, therefore, disclaims all warranties not set forth above, both express and implied, with respect to the *DL107 NET, DL107 NET D, DL207 NET, DL207 NET D, DL210 NET 2.0, and DL210 NET D 2.0 Digi-Loop™ DSP Induction Loop Amplifiers*, including but not limited to, any implied warranty of merchantability or fitness of use of such equipment including, without limitation, any warranty that the use of such equipment for any purpose will comply with applicable laws and regulations. Williams AV shall not be liable to any person or entity for any medical expenses or any direct, incidental or consequential damages caused by any use, defect, failure or malfunctioning of the product, whether a claim for such damages is based upon warranty, contract, tort or otherwise, the sole remedy for any defect, failure or malfunction of the products is replacement of the product. No person has any authority to bind Williams AV to any representation or warranty with respect to the *DL107 NET, DL107 NET D, DL207 NET, DL207 NET D, DL210 NET 2.0, and DL210 NET D 2.0 Digi-Loop™ DSP Induction Loop Amplifiers*. Unauthorized repairs or modifications will void the warranty. This warranty is void if damage occurred because of misuse, or if the product has been repaired or modified by anyone other than a factory authorized service technician. Warranty does not cover normal wear and tear on the product or any other physical damage unless the damage was the result of a manufacturing defect. Williams AV is not liable for consequential damages due to any failure of equipment to perform as intended. Williams AV shall bear no responsibility or obligation with respect to the manner of use of any equipment sold by it.

This warranty does not cover reimbursement for your costs of removing and transporting the product for warranty service evaluation or installation of any replacement product provided under this warranty.

The exclusions and limitations set out above are not intended to, and should not be construed so as to contravene mandatory provisions of applicable law. If any part or term of this Disclaimer of Warranty is held to be illegal, unenforceable, or in conflict with applicable law by a court of competent jurisdiction, the validity of the remaining portions of this Disclaimer of Warranty shall not be affected, and all rights and obligations shall be construed and enforced as if this Limited Warranty did not contain the particular part or term held to be invalid. The terms of the warranty are governed by the laws of the State of Minnesota.

Prices and the specifications of the products are subject to change without notice.

*For Complete Warranty Statement go to: www.williamsav.com/warranty-statement

NOTICE: Williams AV products are NOT designed for use in extreme temperature, humidity or chemical environments. The introduction of chemicals such as chlorine, salt water or human sweat into the product will cause damage to the circuitry. Damage due to these causes is NOT covered under the Product Warranty.

If you experience difficulty with your system, call Toll-Free for Customer Assistance 1-800-843-3544 (U.S.A.) or +1 952 943 2252 (Outside the U.S.A.)

If it is necessary to return the system for service, your Customer Service Representative will give you a Return Authorization Number (RA) and shipping instructions.

WILLIAMS AV

info@williamsav.com / www.williamsav.com
800-843-3544 / INTL: +1-952-943-2252

© 2020, Williams AV, LLC MAN 202L