



**MOUNT
 BT8390 RAILS TO
 A WALL OR ONTO
 A COLUMN**

BT8390-WFK3 SYSTEM X™ DUAL RAIL MOUNTING BRACKET

The BT8390-WFK3 is a bracket designed to fix two BT8390 mounting rails onto walls or vertical support columns, for the installation of large format displays. The bracket is ideal for reducing installation times, by eliminating the need to measure the distance between mounted rails.

SPECIFICATION

Recommended interface arms BT8390-VESA800F & BT8390-VESA1200F

Distance from wall to front of rail 36mm

Distance between rails 480mm

Brackets supplied per pack 1

Quantity of brackets required per rail length (landscape installs):*

Rail Length	Qty
0 - 2000mm	2pcs
2001 - 3500mm	3pcs
3501 - 5500mm	4pcs
5501 - 7750mm	5pcs
7751 - 8500mm	6pcs

*Use B-Tech's online configuration tool to automatically calculate the quantity required based on your configuration. www.btechavmounts.com/systemx-configurator

FEATURES

- Designed to dual mount BT8390 horizontal mounting rails to the wall
- Reduces install times by eliminating the need to measure the distance between mounted rails
- Can also be used with BT8380 vertical columns to create freestanding videowalls
- Keyhole fixings for quick and easy installation
- All mounting hardware included

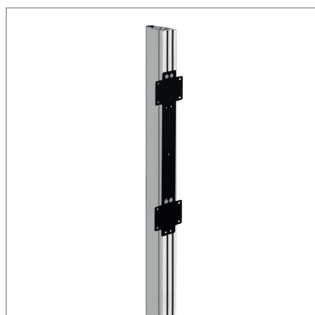

Can also be used for video wall installations that use Vertical Support Columns

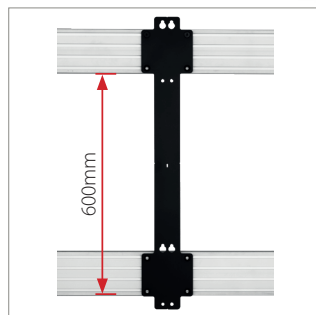

Dramatically reduces install times by eliminating the need to measure the distance between the rails

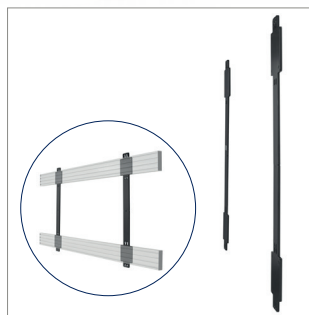

Low profile design for a close to the wall installation



Single Rail Mounting Brackets are also available, please see BT8390-WFK1 & BT8390-WFK2



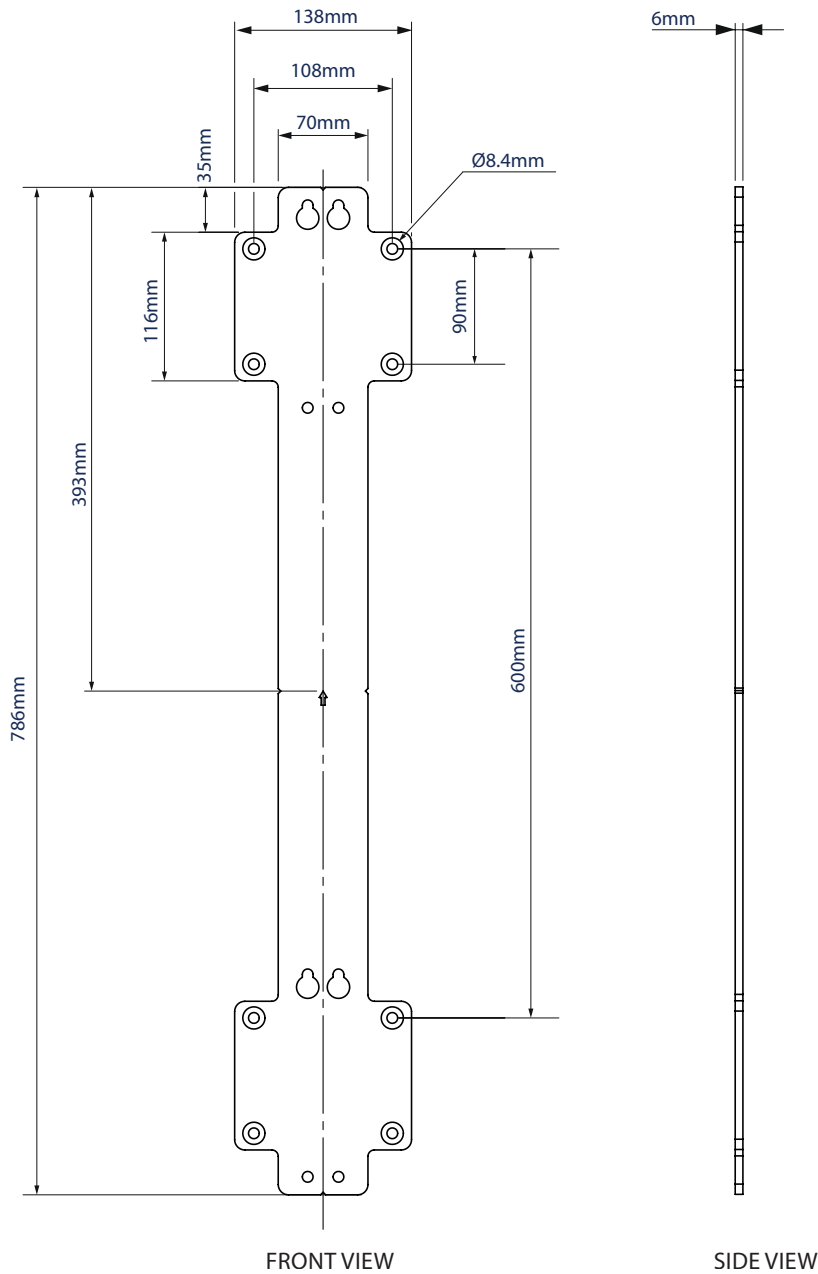

FRONT VIEW

SIDE VIEW

PACKING INFORMATION

COLOUR:	ORDER REF:	EAN CODE:	MASTER CARTON QTY:	INNER CARTON QTY:	MASTER CARTON WEIGHT:	MASTER CARTON CUBE:
Black	BT8390-WFK3/B	5019318501456	1	0	2kg	0.012cbm

ACCESSORIES AND RELATED PRODUCTS

BT8390-030/050/070/150/175/200

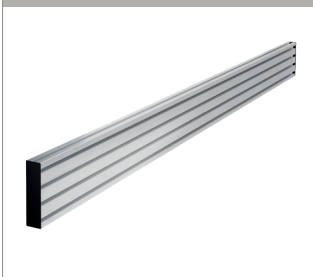

Mounting Rails can be fixed to columns, walls or poles using System X components

BT8380-060/180

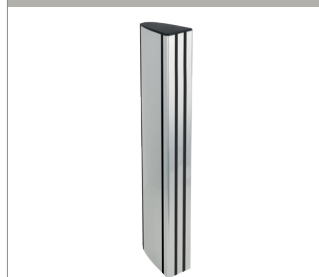

Vertical Support Columns for freestanding, mobile or bolt-down screen mounting

BT8390-VESA800F

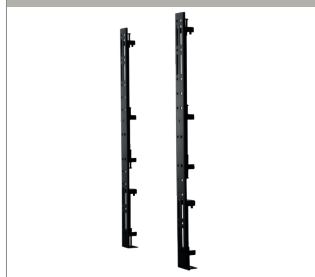

BT8390-VESA800F are XL interface arms designed for mounting screens using VESA fixings up to 800

BT8390-VESA1200F



BT8390-VESA1200F are XXL interface arms designed for mounting screens using VESA fixings up to 1200

© 2015 B-Tech Professional Design & Manufacturing Ltd. All rights reserved. The information in this specification sheet reflects the current technical specifications at the time of print. We reserve the right to change the technical or physical specifications without prior notice. This is not intended to constitute a contract. B-Tech Professional Design & Manufacturing Ltd. is not liable for loss or damage caused by improper installation or mounting on unsuitable structures. Any reproduction or transmission or replication of any part of this specification is expressly prohibited, unless prior written permission has been granted by B-Tech Professional Design & Manufacturing Ltd. BDC

SS-V2-BT8390-WFK3-130521