



IDEAL FOR
 PORTRAIT OR
 LANDSCAPE
 INSTALLS

BT8390-VESA800F SYSTEM X™ UNIVERSAL INTERFACE ARMS FOR XL SCREENS

These interface arms are designed to mount XL screens in a fixed position across one or two System X horizontal mounting rails. The universal design is compatible with a variety of different screens and allows them to be mounted in either landscape or portrait orientations. Levelling screws on each interface arm provide post installation height adjustment and a mounted depth of 51.5mm from the wall allows easy access for cables and connectors.

SPECIFICATION

Recommended screen size (landscape)	72" and over
Recommended screen size (portrait)	42" and over
Max load (single rail mounting)	70kg
Max load (twin rail mounting)	200kg
VESA® & non-VESA fixings	up to 800mm* (vertical dimension)
Depth from wall (when rail mounted)	51.5mm
Colour	Black

Supplied in pairs

*The VESA specification of the BT8390-VESA800F refers to the vertical dimension only. All System X interface arms can be positioned as far along the rail as necessary.

FEATURES

- Heavy duty arms capable of supporting substantial loads
- Suitable for landscape or portrait mounting
- Can be mounted across single or dual horizontal mounting rails to suit the application
- Lateral adjustment - position arms anywhere along the length of the rail
- Includes levelling screws to adjust the screen height
- Safety screws help prevent unauthorised removal of screens
- Simple 'hook-on' installation

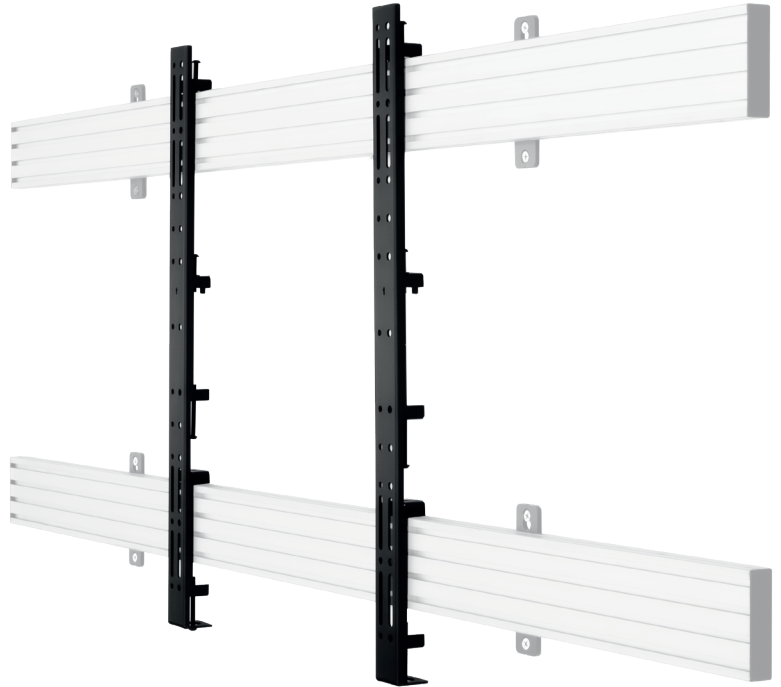

Single Rail

Dual Rail

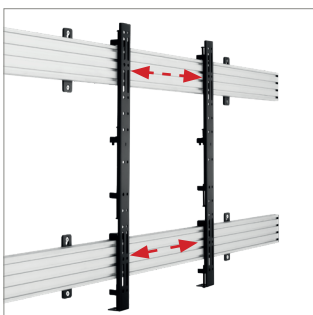

Position arms anywhere along the length of the rail

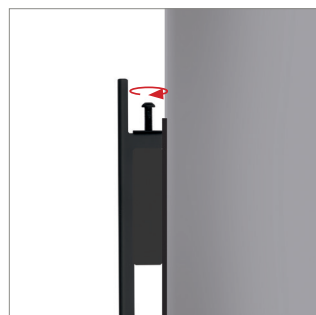

Arms feature levelling screws to adjust the screen height

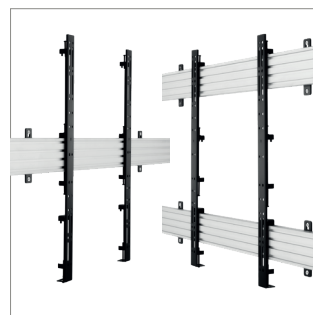

Can be mounted across single or dual horizontal mounting rails to suit the application



Compatible with the System 2 range of poles and collars for pole mounted installations

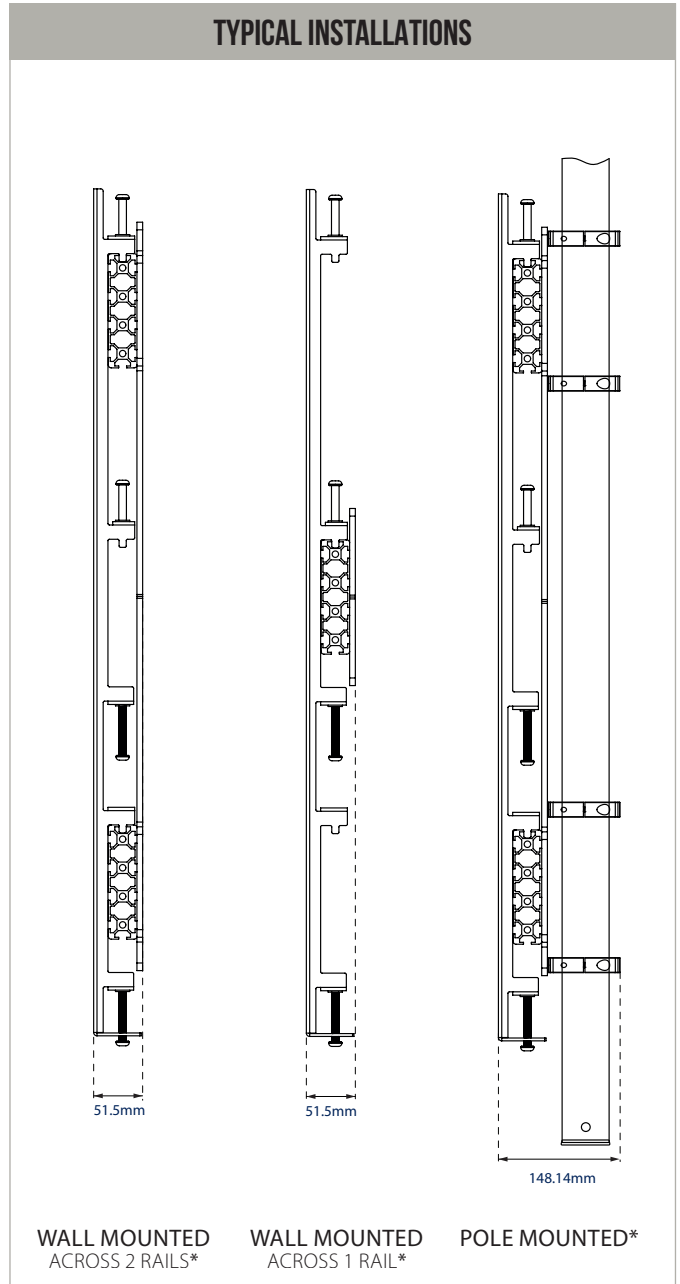
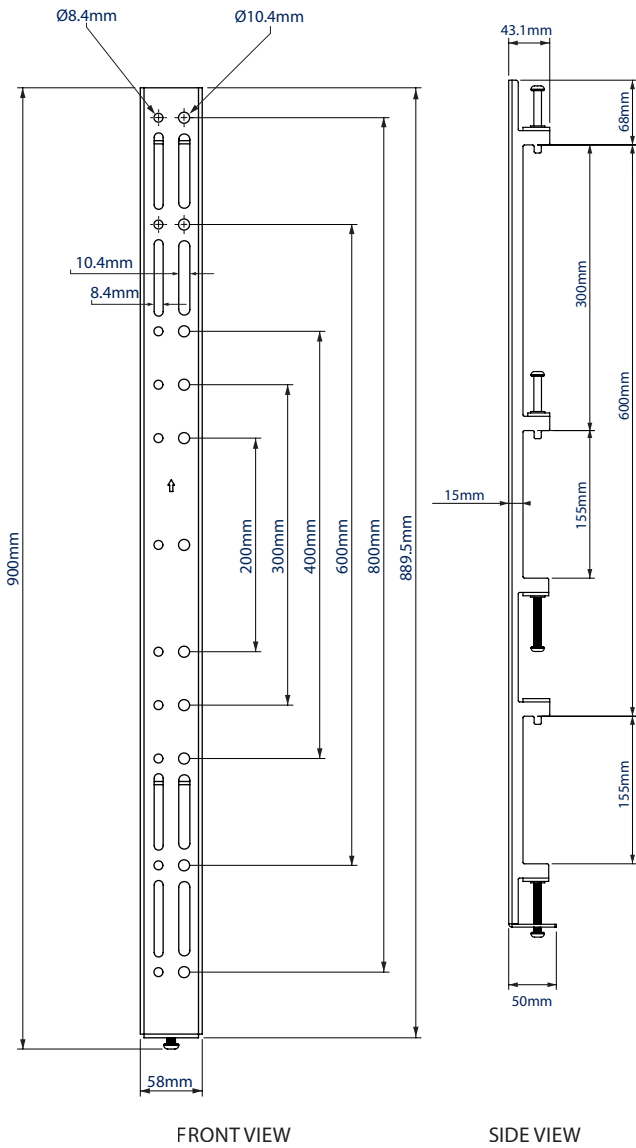

*Please note all other components shown in the technical drawings are available separately.

PACKING INFORMATION

COLOUR:	ORDER REF:	EAN CODE:	MASTER CARTON QTY:	INNER CARTON QTY:	MASTER CARTON WEIGHT:	MASTER CARTON CUBE:
Black	BT8390-VESA800F/B	5019318501432	1	0	5kg	0.006cbm

ACCESSORIES AND RELATED PRODUCTS



BT8390-WFK3 Wall Fixing Kit has been designed for BT8390-VESA800F & BT8390-VESA1200F arms to eliminate alignment calculations when mounting across 2 parallel horizontal rails



BT8390-WFK1 Wall Fixing Kit can also be used with BT8390-VESA800F arms when mounting across one horizontal rail alignment calculations when mounting across 2 parallel horizontal rails



Mounting Rails can be fixed to columns, walls or poles using System X components



Universal Interface Arms For XXL Screens capable of supporting substantial loads of up to 200kg

© 2015 B-Tech Av Mounts. Design & Manufacturing Ltd. All rights reserved. The information in this specification sheet reflects the current technical specifications at the time of printing. We reserve the right to change the technical or physical specifications without prior notice. This information is provided for informational purposes only and does not constitute an offer or a contract. B-Tech Av Mounts is not liable for loss or damage caused by improper installation or mounting on unsuitable structures. Any reproduction or transmission or explanation of any part of this specification is expressly prohibited unless prior written permission has been granted by B-Tech Av Mounts Design & Manufacturing Ltd. B-Tech Av Mounts Design & Manufacturing Ltd.

SS-V2-VESA800F-130521