



BT8370

SYSTEM X™

UNIVERSAL VIDEO WALL STAND

INSTALLATION GUIDE & PARTS LIST

This Pack Contains 1 Stand

PLEASE KEEP THIS FOR FUTURE REFERENCE



FEATURES

- Universal stand suitable for video wall screens from 32" - 70" (81cm - 177cm)
- Max weight per screen: 50kg (110lbs)
- Designed for screens with VESA® & non-VESA mounting patterns
- Suitable for landscape or portrait screen mounting
- Collar compatible accessories such as shelves can be fitted directly to the extrusion
- Integrated cable management
- All mounting hardware included

This assembly manual covers different installations. Please note that some parts or procedures shown may not be required for installation.



Per Screen

CONTENTS

Installation Safety Notes.....	2
Parts List.....	4
Installation Notes.....	6
Installation Instructions.....	10
Optional Accessories.....	23
B-Tech Contact Details.....	24

INSTALLATION TOOLS REQUIRED

Crosshead screwdriver



10mm Spanner



Level



Knife



B-TECH AV MOUNTS

www.btechavmounts.com

INSTALLATION SAFETY INSTRUCTIONS



CAUTION: This stand is intended for use only with the maximum weights indicated. Use with flat screens heavier than the maximum indicated may result in instability causing possible injury.

Do not attempt to install this product until all instructions and warnings have been read and properly understood. Please keep these instructions for future reference.

Please check carefully to make sure there are no missing or defective parts - defective parts must never be used. B-Tech International Design & Manufacturing Ltd, its distributors and dealers are not liable or responsible for damage or injury caused by improper installation, improper use or failure to observe these safety instructions. In such cases, all guarantees will expire.

General

Great care must always be taken during installation as most AV equipment is of a fragile nature, possibly heavy and easily damaged if dropped.

If you do not fully understand the instructions or are not sure how to install this product safely, then please consult a professional for advice and/or to install this product for you. Failure to mount this product correctly may cause serious injury or death both during installation and at any time thereafter. Do not mount any AV equipment that exceeds the specific weight limit of the product you are installing. This weight limit will be clearly stated on each product and its packaging and will vary from product to product.

Product location

Please pay careful attention to where this product is located, some locations are not suitable for installation. For indoor use only. Install stand on level ground. When verifying the stability of the structure, consider the following external factors: The strength of the floor, exposure to sudden and severe wind and danger arising from contact with people and / or objects (eg installations in passageways, emergency exits), if located in a public or frequently populated area ensure that the product is out of the immediate reach of people.

Fixing hardware

It is highly recommended that all fixing screws be used where supplied and that the purpose of all other fixing hardware is fully understood. In some cases more AV equipment fixing hardware will be supplied to accommodate different models of equipment and set up configurations.

The installer must be satisfied that any supplied fixing hardware is suitable for each specific installation. If any fixing screws or included hardware are deemed not sufficient for a safe installation then please consult a professional or your local hardware store.

Hazard limitation

When routing cables take advantage of any built in cable management features that the product might provide and ensure that all cables are tidy and secure. Check to see that any moving aspect of the product can do so unhindered by any cabling.

Some products have moving parts and the potential to cause injury through the crushing or trapping of fingers or other body parts.

Particular attention to the nature of moving parts is required especially when assembling installing and adjusting during set up.

Immediately after installations double-check that the work done is safe and secure. Double-check all necessary fixings are present and are of ample tightness.

It is recommended that periodic inspections of the product and its fixing points are made as frequently as possible to ensure that safety is maintained. If in doubt consult a professional AV installer or other suitably qualified person.

CS

Společnost B-Tech International Design And Manufacturing Ltd. doporučuje provést instalaci tohoto produktu instalátora AV či jinak způsobilé osoby. Společnost B-Tech International Design And Manufacturing Ltd, její distributoři a prodejci nenesou prostřednictvím odborného odpov ědnost za škody nebo zranění způsobená nevhodnou instalací. Tento výrobek je nutno umístit do vhodné konstrukce a používat jen po uvedené maximální výšce.

DE

B-Tech International Design And Manufacturing Ltd. empfiehlt, dass dieses Produkt durch einen qualifizierten AV-Techniker oder eine andere Person mit geeigneter Qualifikation installiert wird. B-Tech International Design And Manufacturing Ltd, ihre Distributoren und Händler können nicht für durch fehlerhafte Montage verursachte Beschädigung oder Verletzung haftbar bzw. verantwortlich gemacht werden. Dieses Produkt muss auf eine geeigneten Untergrund montiert werden und darf nur bis zum angegebenen Höchstgewicht verwendet werden.

ES

B-Tech International Design And Manufacturing Ltd. recomienda que un instalador de audio y video profesional u otra persona debidamente cualificada instalen este producto. B-Tech International Design And Manufacturing Ltd, sus distribuidores y concesionarios no se hacen cargo ni se responsabilizan de ningún daño o lesión provocados por una instalación inapropiada. Este producto se debe montar en una estructura adecuada y se debe utilizar soportando solamente hasta el peso máximo indicado.

FR

B-Tech International Design And Manufacturing Ltd. recommande de confier l'installation de ce produit à un installateur AV professionnel ou à une autre personne dûment qualifiée. B-Tech International Design And Manufacturing Ltd, ses distributeurs et ses revendeurs ne sauraient être tenus responsables de tout dégât ou de toute blessure résultant d'une installation incorrecte. Ce produit doit être monté sur un support approprié et utilisé dans la limite du poids maximum indiqué.

IT

B-Tech International Design And Manufacturing Ltd. consiglia di affidare l'installazione di questo prodotto a un installatore specializzato o ad altra persona adeguatamente qualificata. B-Tech International Design And Manufacturing Ltd. i suoi distributori e rivenditori non accettano alcuna responsabilità nei riguardi di eventuali danni o infortuni causati da un'errata installazione. Questo prodotto deve essere fissato a una struttura idonea e utilizzato unicamente sino al peso massimo indicato.

NL

B-Tech International Design And Manufacturing Ltd. adviseert om dit product te laten installeren door een professionele AV-installateur of andere hiervoor gekwalificeerde persoon. B-Tech International Design And Manufacturing Ltd, haar distributeurs en dealers zijn niet aansprakelijk of verantwoordelijk voor schade of letsel die is veroorzaakt door onoordeelkundige installatie. Dit product moet worden gemonteerd aan een geschikte constructie, waarbij het aangegeven maximum gewicht niet mag worden overschreden.

PL

Firma B-Tech International Design And Manufacturing Ltd. zaleca, aby ten produkt był instalowany przez profesjonalnych instalatorów AV lub inny odpowiednio przeszkolony personel. Firma B-Tech International Design And Manufacturing Ltd, jej dystrybutorzy i dealerzy nie ponoszą odpowiedzialności za uszkodzenia lub obrażenia ciała powstałe w wyniku nieprawidłowej instalacji. Niniejszy produkt musi być zamontowany na odpowiedniej powierzchni, a podczas u żytkowania nie wolno przekraczać podanego maksymalnego obciążenia.

PT

A B-Tech International Design And Manufacturing Ltd. recomenda que a instalação deste produto seja efectuada por um instalador de AV instalador de AV profissional ou outra pessoa devidamente habilitada. A B-Tech International Design And Manufacturing Ltd. e os seus distribuidores e concessionários não são responsáveis por danos ou lesões causados por uma instalação incorrecta. Este produto tem de ser montado numa estrutura adequada e utilizado somente até ao peso máximo indicado.

RU

Компания B-Tech International Design And Manufacturing Ltd. рекомендует, чтобы установка данного изделия производилась инженером по установке аудио-видеотехники или другим специалистом с соответствующей квалификацией. Компания B-Tech International Design And Manufacturing Ltd. ее дистрибьюторы и дилеры не несут ответственности за повреждения или травмы, полученные в результате неправильной установки. Данное изделие должно

توصي بي- تك للتجارة الدولية المحدودة بأن شخص محترف في تركيب ال AV او شخص مؤهل تأهيلا مناسباً لتركيب هذا المنتج بي- تك للتجارة الدولية، موزعيها والتجار ليست عرضة أو مسؤولة عن الأضرار أو الإصابات الناجمة عن تركيب غير سليم، والاستخدام غير السليم أو عدم مراعاة هذه التعليمات للسلامة. يجب أن يتم تركيب هذا المنتج في بنية مناسبة ويجب استخدامه فقط لدعم الحد الأقصى للوزن المشار إليه.

BT8370 PARTS LIST

Due to the multiple installations available each option below is dependent on the stand ordered.

PLEASE KEEP THIS FOR FUTURE REFERENCE

(A) BASE

BT8380-BASE BT8380-SHB

ITEM	PART NAME	QTY PER PACK
A1	BASE	1
A2	SUPPORT STEM*	1
A3	M8 x 90mm SCREW*	4
A4	M8 WASHER	2
A5	LEVELLING FOOT	2
A6	6AF HEX KEY	1
A7	SPANNER	1
A8	M8 x 65mm SCREW**	2
A9	M8 x 35mm SCREW**	2

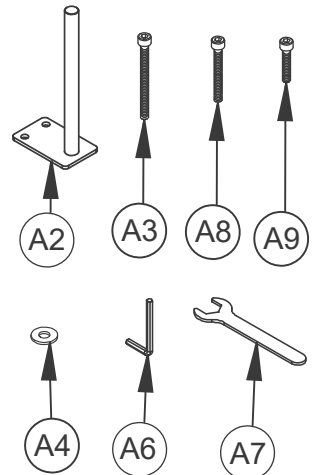
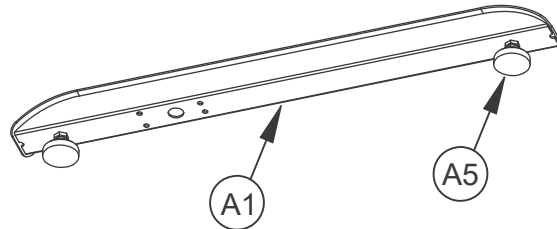

*Supplied with the BT8380-BASE
**Supplied with the BT8380-SHB

(B) COLUMN

BT8380-180 BT8380-060
Height: 180cm Height: 60cm

ITEM	PART NAME	QTY PER PACK
B1	VERTICAL COLUMN	1
B2	END CAP*	1
B3	CABLE COVER	3
B4	PLASTIC SLOT INSERT	4
B5	M8 SLIDING NUT*	2
B6	M8 x 12mm SCREW*	2
B7	COLUMN JOINER**	4
B8	GRUB SCREW**	16
B9	M6 x 10mm HEX BOLT**	8
B10	3AF HEX KEY**	1

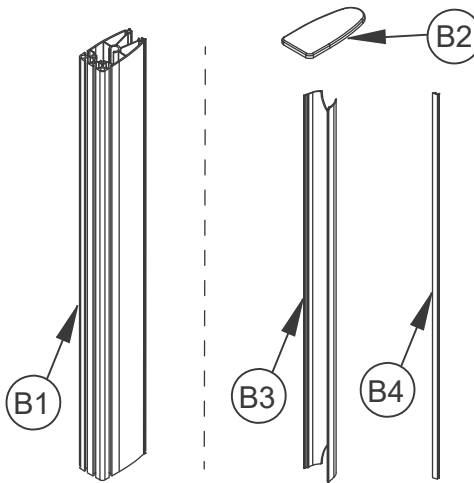

Optional
*To fix shelves to a column

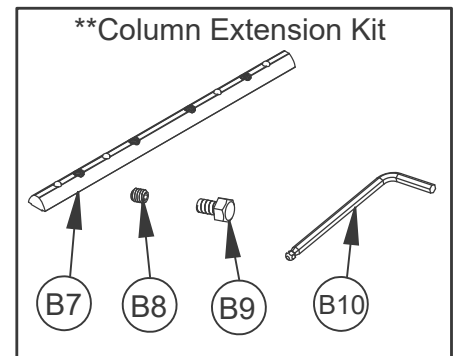
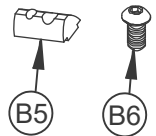

*Supplied with the BT8380-180
**Supplied with the BT8380-060

(C) JOINING PLATE

BT8380-JPK

ITEM	PART NAME	QTY PER PACK
C1	JOINING PLATE	1
C2	M8 SLIDING NUT	8
C3	M8 x 12mm SCREW	4
C4	5AF HEX KEY	1

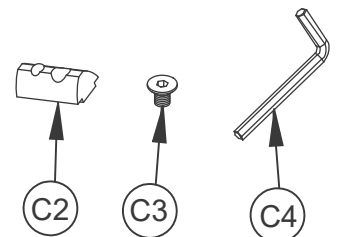
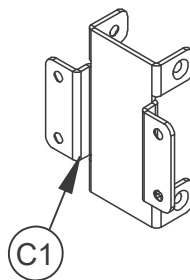

(D) MOUNTING RAIL

BT8390-050 Length: 50cm	BT8390-070 Length: 70cm
BT8390-150 Length: 150cm	BT8390-175 Length: 175cm
BT8390-200 Length: 200cm	BT8390-300 Length: 300cm

ITEM	PART NAME	QTY PER PACK
D1	MOUNTING RAIL	1
D2	END CAP	2

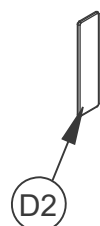
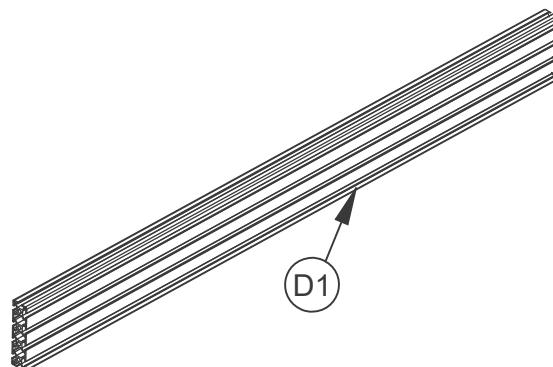

(E) SPACER

BT8390-SP

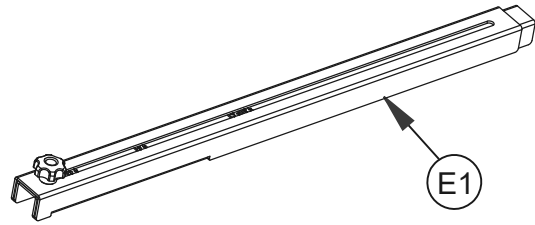

ITEM	PART NAME	QTY PER PACK
E1	SPACER	1

(F) OPTIONAL RAIL EXTENSION KIT

BT8390-EXT

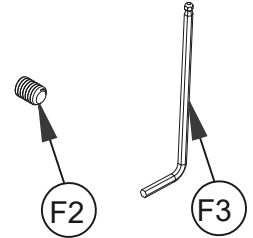
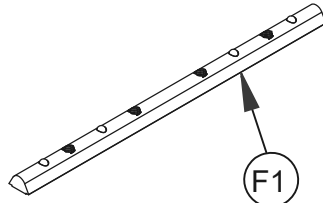

ITEM	PART NAME	QTY PER PACK
F1	JOINING BAR	6
F2	M6 x 8mm GRUB SCREW	24
F3	3AF HEX KEY	1

(G) INTERFACE KIT

ITEM	PART NAME	QTY PER PACK
G1	SCREEN INTERFACE ARM	2
G2	M6 x 8mm HEX SCREW	2
G3	ADJUSTABLE BRACE	1
G4	M5 x 6mm SCREW	2
G5	M6 x 35mm SCREW	2
G6	3AF HEX KEY	1
G7	4AF HEX KEY	1
G8	5AF LONG HEX KEY	1

ITEM	SCREEN FIXING KIT	QTY PER PACK
A	M4 x 12mm SCREW	4
B	M4 x 25mm SCREW	4
C	M4 x 40mm SCREW	4
D	M6 x 16mm SCREW	4
E	M6 x 25mm SCREW	4
F	M6 x 40mm SCREW	4
G	M8 x 16mm SCREW	4
H	M8 x 25mm SCREW	4
I	M8 x 40mm SCREW	4
J	MULTIWASHER	4
K	5mm SPACER	4
L	13mm SPACER	4
M	24mm SPACER	4
N	M6 WASHER	4

Screen Interface Arms

BT8390-VESA200F

BT8390-VESA400F

BT8390-VESA400MAF

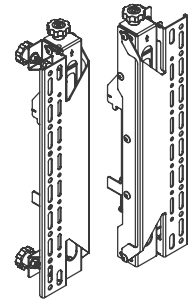
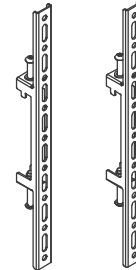
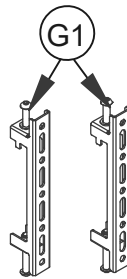

BT8390-VESA200T

BT8390-VESA400T

BT8390-VESA400MAP

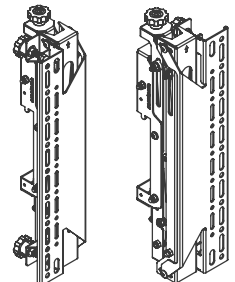
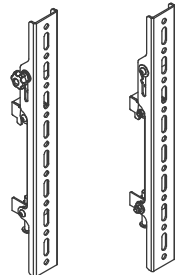
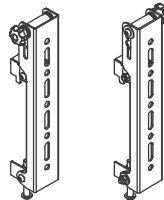

Interface Arm Kit

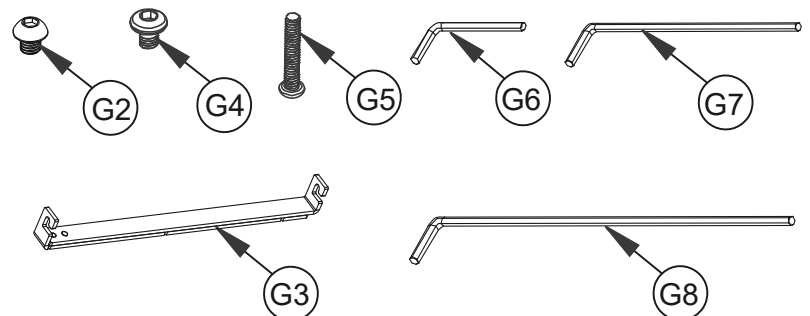

Screen Fixing Kit

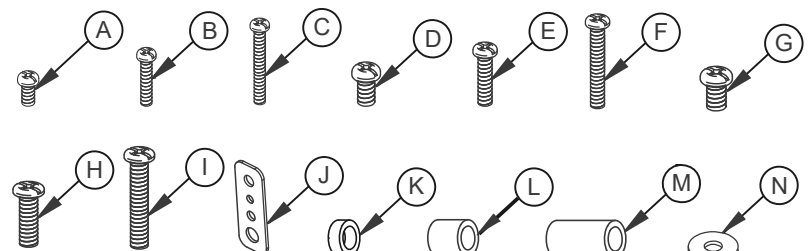

(H) OPTIONAL INTERFACE ADAPTOR ARMS

BT7564 | BT7565 | BT7566

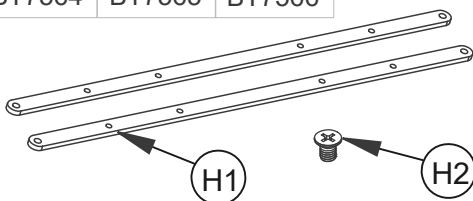

ITEM	PART NAME	QTY PER PACK
H1	ADAPTOR ARMS	2
H2	M8 x 12mm SCREW	4

Please refer to individual parts list for more information

INSTALLATION NOTES

FLOORSTAND STABILITY

⚠ !!! WARNING - DANGER !!! ⚠

- Install stand on level ground
- Minimum two person assembly

When verifying the stability of the structure, consider the following external factors:

1. The strength of the floor.
2. Exposure to sudden and severe wind.
3. Danger arising from contact with people and / or objects. (eg installations in passageways, emergency exits).

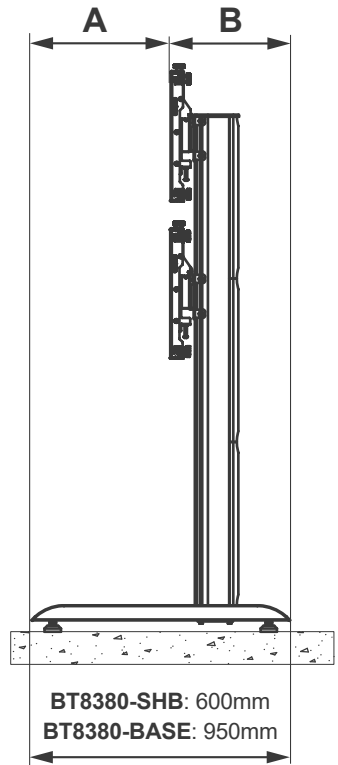

BT8370 DEPTH DIMENSIONS

INTERFACE ARM	BASE: BT8380-SHB		BASE: BT8380-BASE	
	A	B	A	B
BT8390-VESA200F / BT8390-VESA400F	333.6mm	266.4mm	538.6mm	411.4mm
BT8390-VESA200T / BT8390-VESA400T	323.6mm	276.4mm	528.6mm	421.4mm
BT8390-VESA400MAF	295.9mm*	304.1mm*	500.9mm*	449.1mm*
BT8390-VESA400MAP (Closed)	276.6mm*	323.4mm*	481.6mm*	468.4mm*

*+/-10mm Micro-Adjustment

BT8370 MAX LOAD CONFIGURATIONS

MAX COLUMN HEIGHT 4.2M*

(Using the BT8380-BASE)

Max column height using the BT8380-SHB: 1.8m

Note: Screen weight must be evenly spread up the vertical column

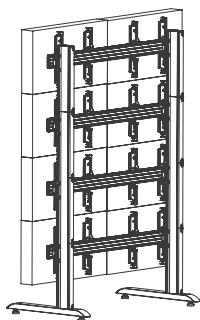

Column height: Up to 2.4m
Max load per screen: 50kg
Max load per vertical column: 200kg

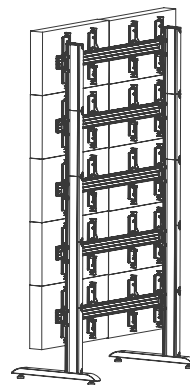

Column height: 3m
Max load per screen: 25kg
Max load per vertical column: 150kg

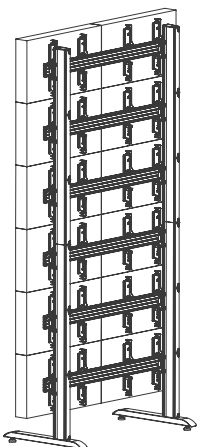

Column height: 3.6m
Max load per screen: 25kg
Max load per vertical column: 150kg

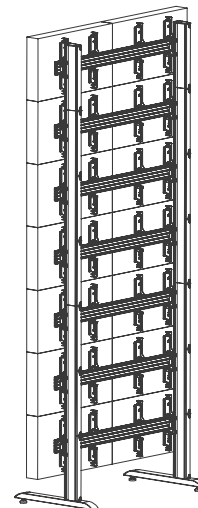

Column height: 4.2m
Max load per screen: 25g
Max load per vertical column: 150kg

NOTE: Larger installs may require the use of a BT8380-WTB (see page 23)

Installing columns with a height over 2.4M

B-Tech recommends when extending the vertical columns over 2.4m to fix the first two columns (item B1) to the bases (item A1) and connect with a horizontal rail (item D1) and then build up, rather than building the product layed down on the floor (as shown in the assembly instructions).

- i. Fix a column to each base and attach the first rail to make the structure stable.
- ii. Attach next vertical columns one at a time and fix with the joining bars.

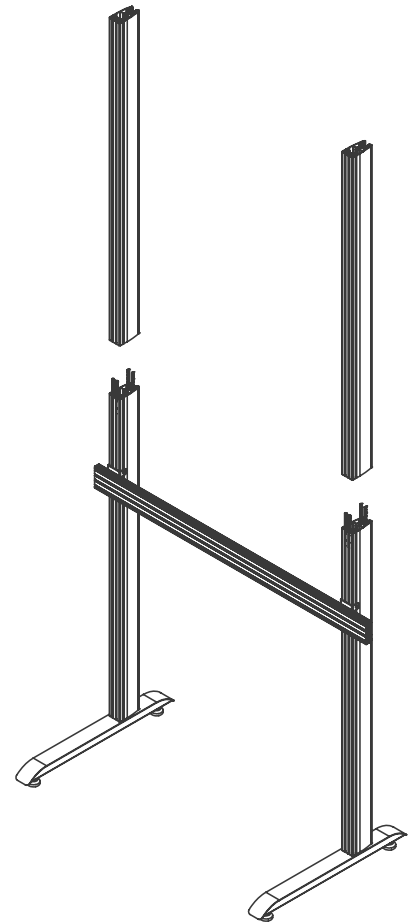
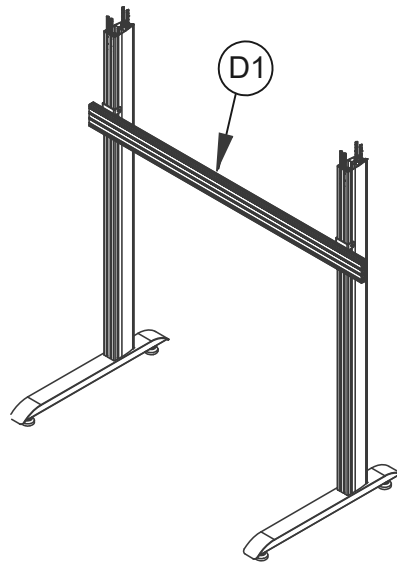
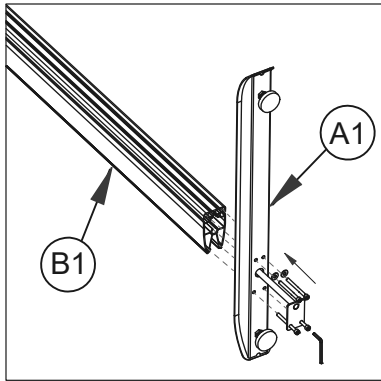

Note: Do not extend columns over 4.2M

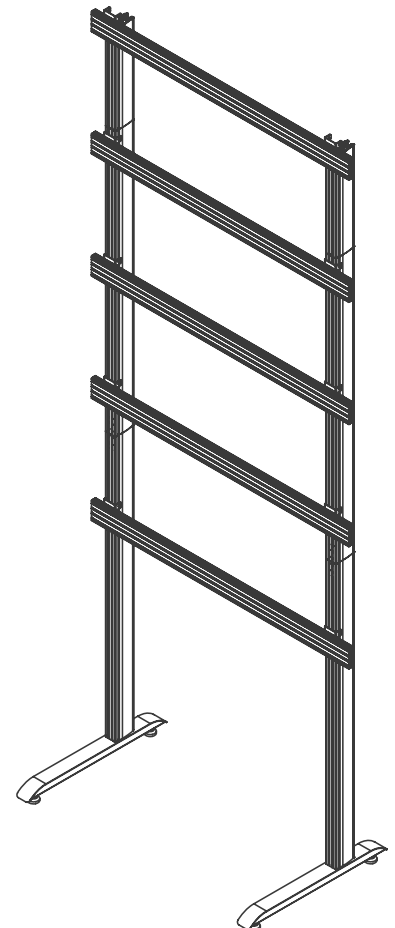
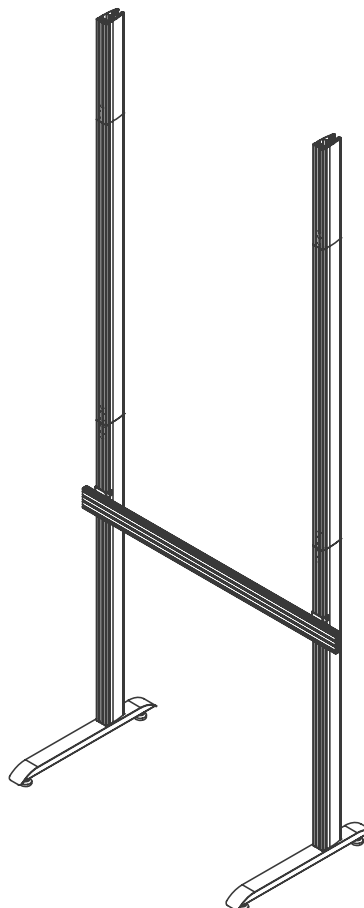
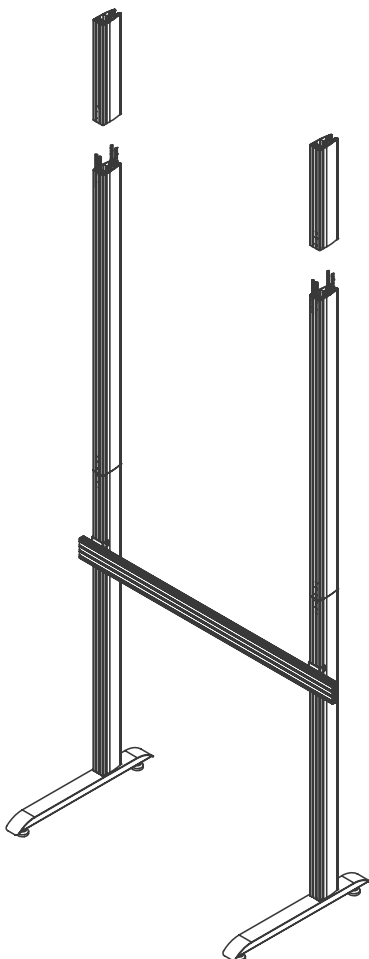

OPTIONAL: EXTENDING THE COLUMNS

- i. Insert the joining bars (item B7) halfway into the non-threaded end of the column (item B1). The two joining bars with grub screws (item B8) go in the front of the column and the 2 joining bars with hex bolts (item 9) go in the back.

IMPORTANT: Joining bars should be inserted into the non-threaded end of the 180cm column.

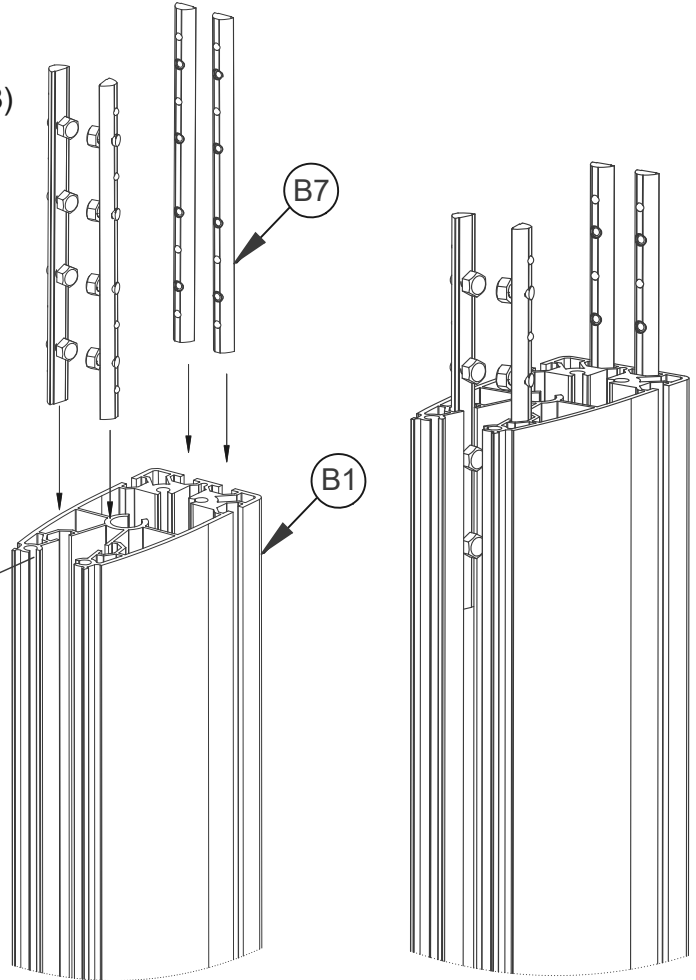
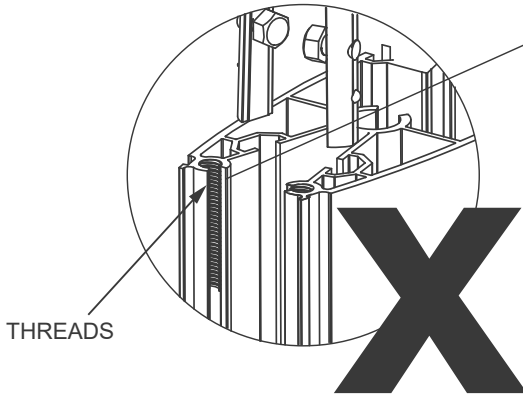

Front of Column

- ii. The two joining bars with grub screws in the front of the column.

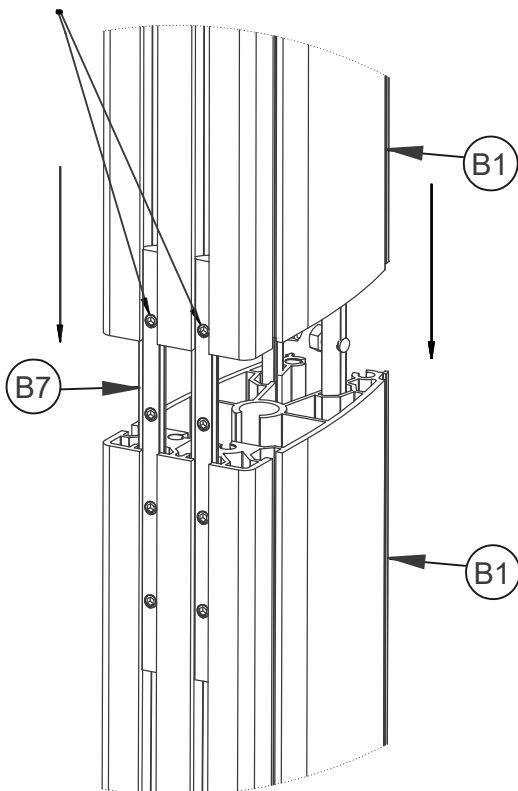

Back of Column

- The two joining bars with hex bolts in the rear of the column.

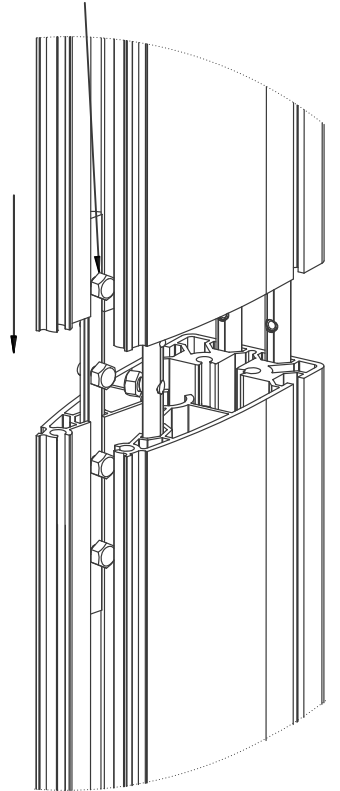

Tighten hex bolts by hand. Finish tightening using a 10mm spanner.

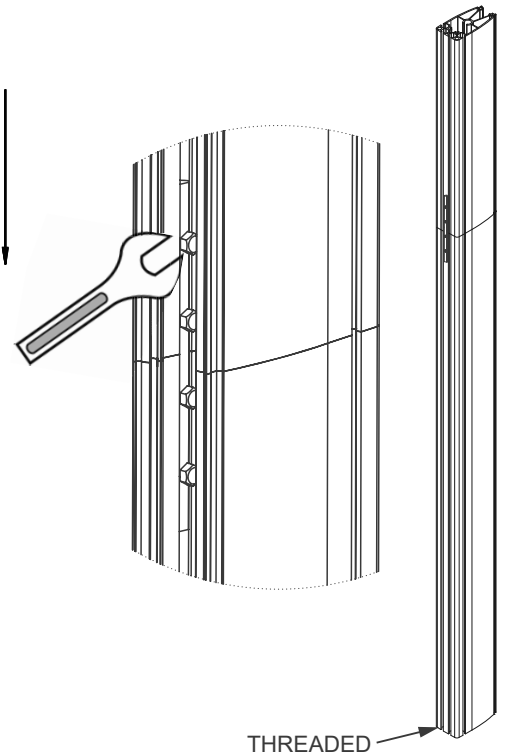

OPTIONAL: EXTENDING THE MOUNTING RAIL

Combine Mounting Rails together using the BT8390-EXT

- i. On the intended front facing side of the mounting rail (item D1) insert 4 x joining bars (item F1) half-way into each slot, on the back side insert 1 x joining bar into the top slot and 1 x joining bar into the third slot (see *fig. 1*). Loosely fasten the 2 grub screws (item F2) on each joining bar fixing it to the mounting rail.
- ii. Slide another mounting rail (item D1) onto the joining bars and tighten all the grub screws, combining the rails securely.

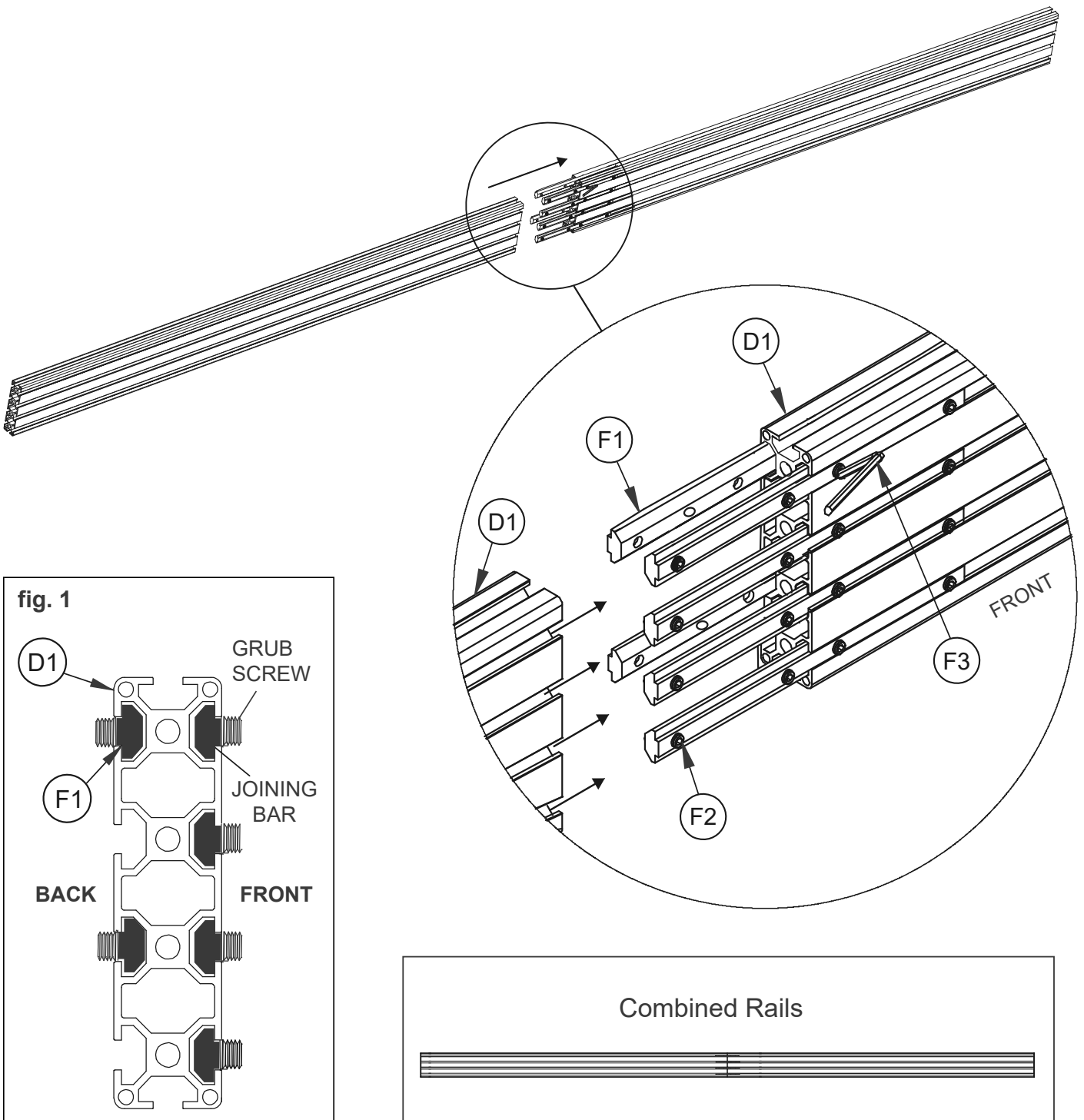

INSTALLATION INSTRUCTIONS

1

Attach Joining Plate to Column

- i. Connect together the M8 x 12mm (item C3) with M8 Sliding Nut (item C2) onto the joining plates (item C1).
- ii. Lay columns (items B1) on the floor and slide on the joining plates (item C1).

i.

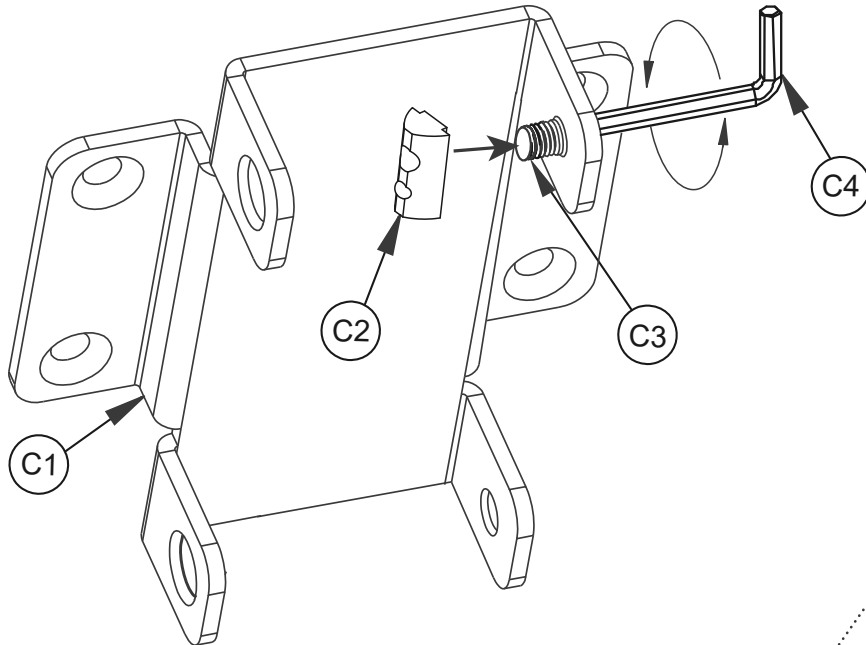

ii.

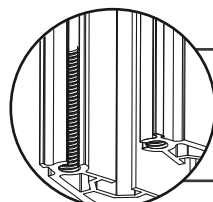
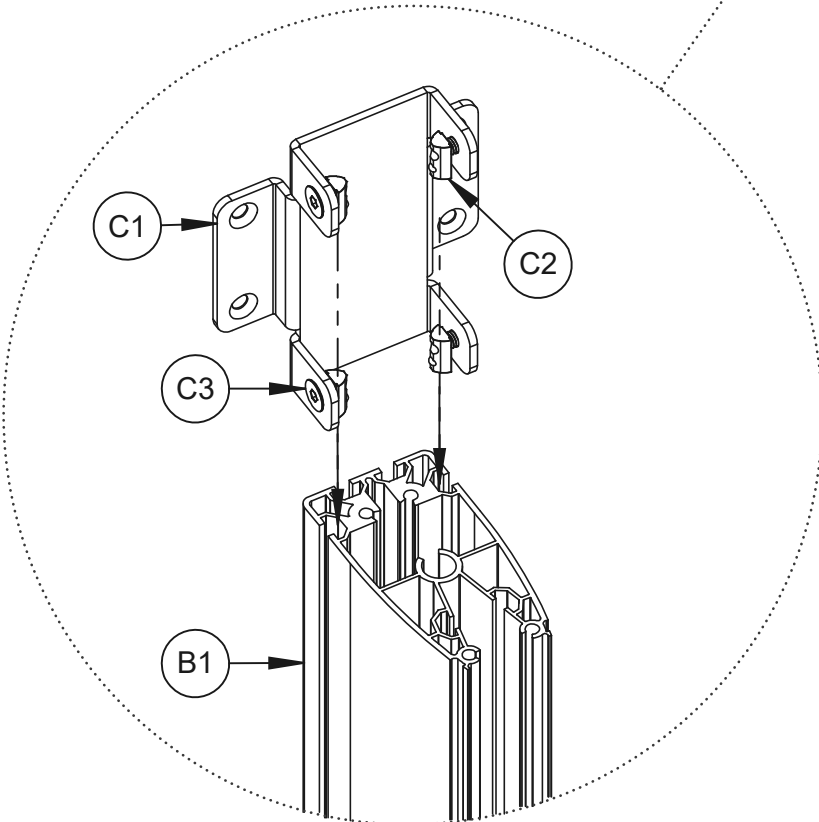
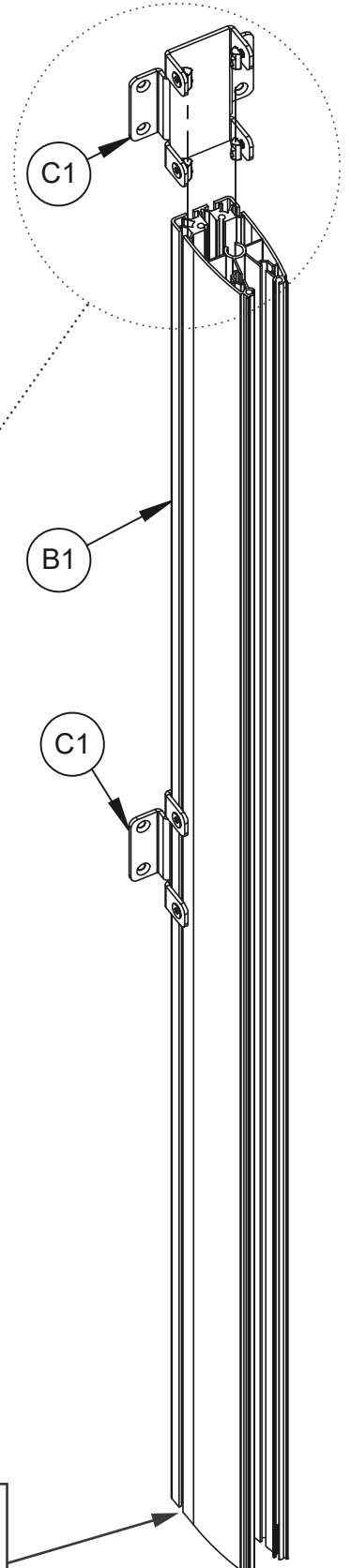

IMPORTANT:
Make sure the end with M8 threads
are at the bottom of the columns.

iii. Use the spacer (item F1) to set the distance between joining plates (items C1) on the column (item B1) according to the screen size. Once set, tighten the M8 x 12mm screws (item C3).

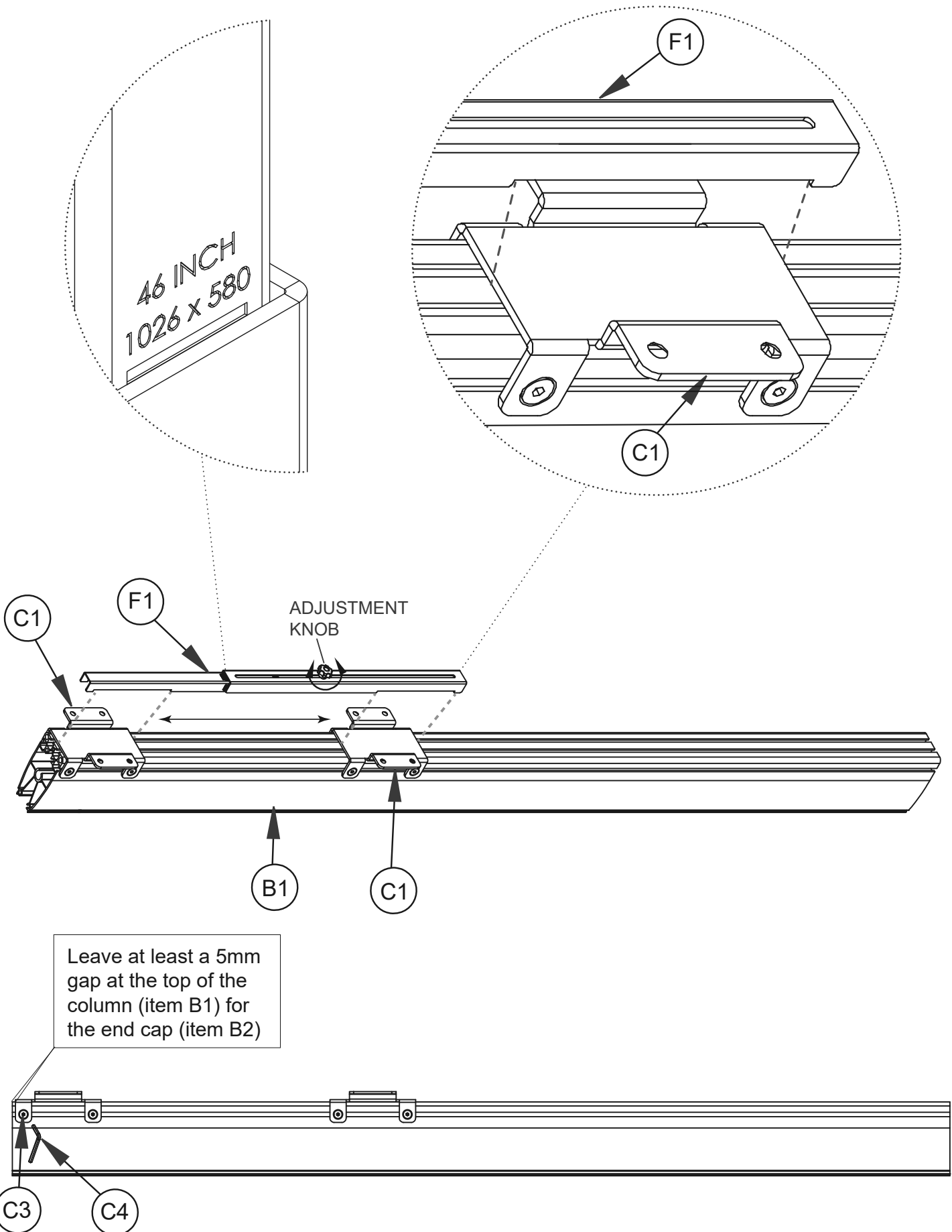

2

Insert Sliding Nuts into Mounting Rails

Lay mounting rails (item D1) on the floor and insert 4 x M8 sliding nuts (item D2).
2 in the second slot, 2 in the bottom slot.

Insert 4 sliding nuts for each joining plate (item D1) to be attached to the rail.

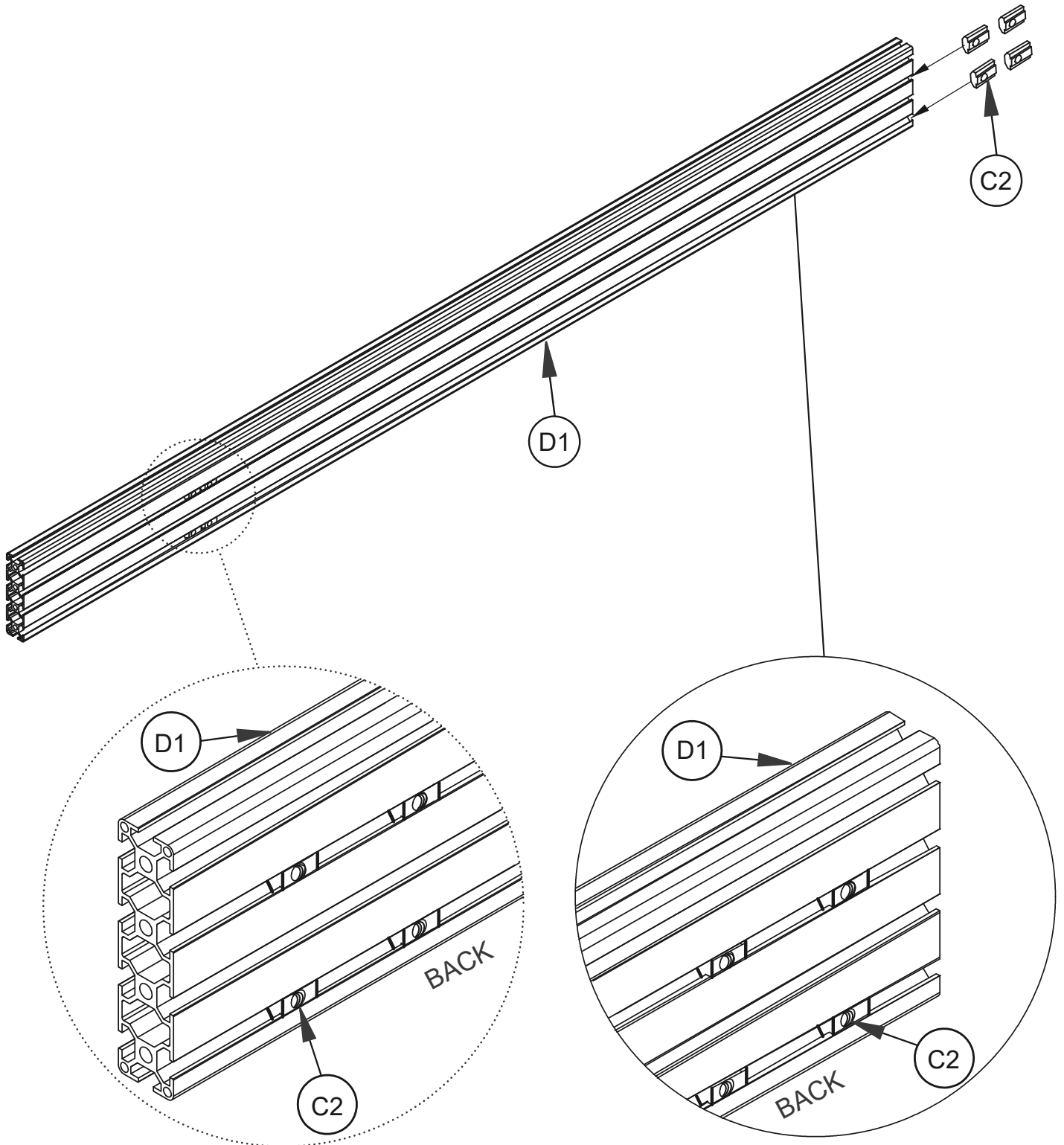

Attach Rails to Columns

On the floor, lay the columns (item B1) face down onto the mounting rails (item D1). Through the joining plates (item D1), fasten the M8 x 12mm screws (item C3) into the M8 sliding nuts (item C2) attaching the mounting rails to the columns.

To ensure straight assembly of columns (item B1), make sure the distance of the outer joining plates (item C1) to the end of the rails (item D1) are set the same on each rail.

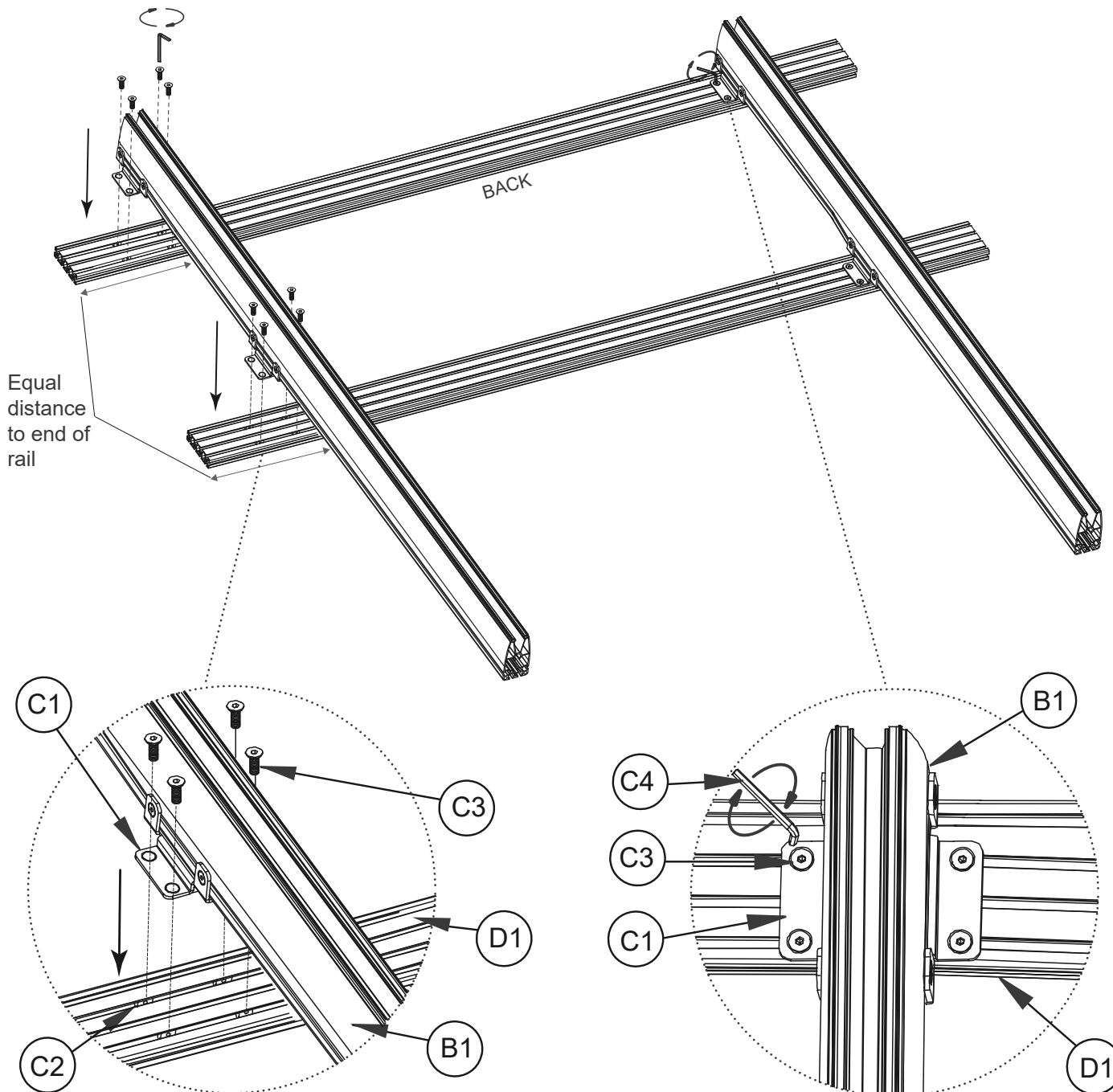
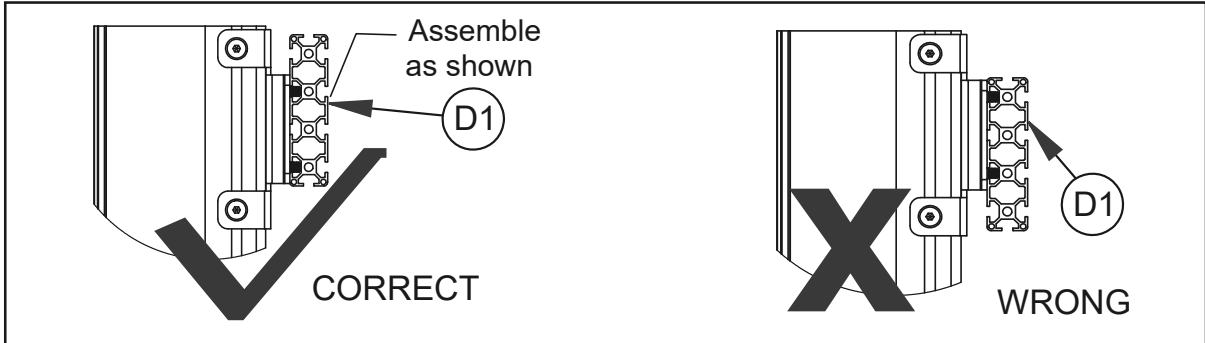

Assemble Bases to Columns

Attach the bases (item A1) to the columns (item B1) using the support stems (item A2), M8 x 90mm screws (item A3) and washers (item A4).

Once bases are fixed, return stand to upright position.

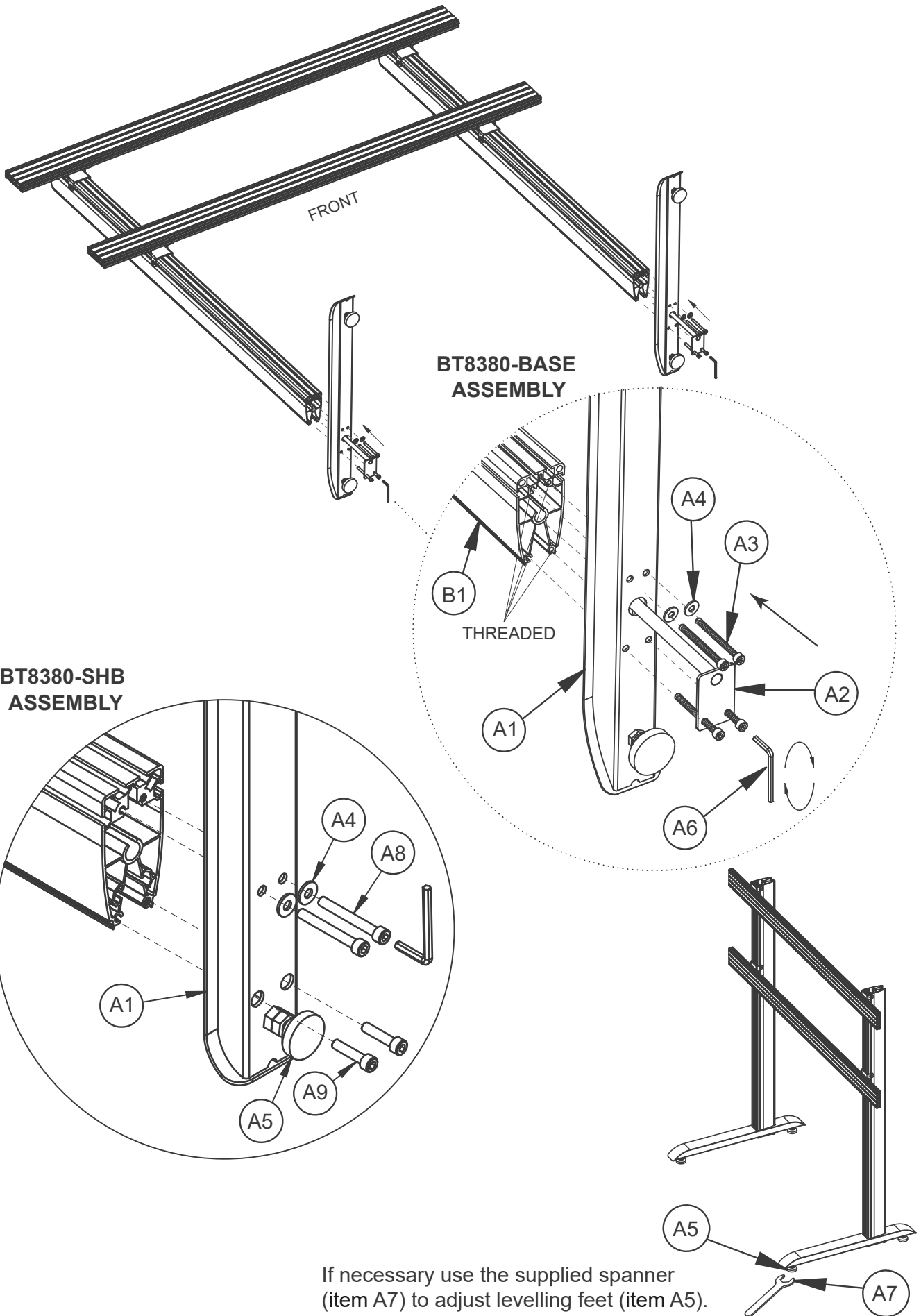

5A

Attaching Fixed and Tilt Interface Arms to the Screens

Attach the interface arms (items G1) to the back of the screen using the screen fixing kit (items A-I). Ensure the arms are positioned the correct way round and the same holes are used on both arms.

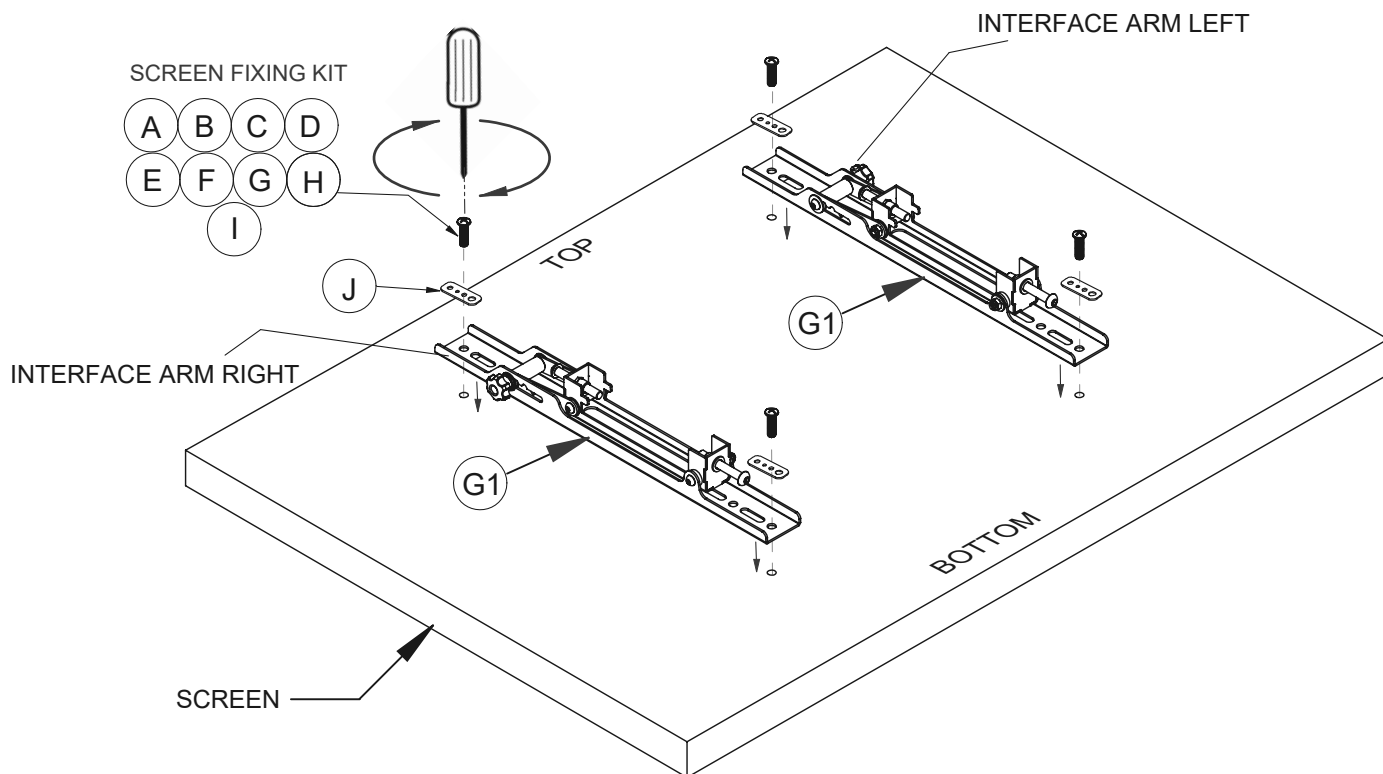

Use spacers for screens with recessed fixings

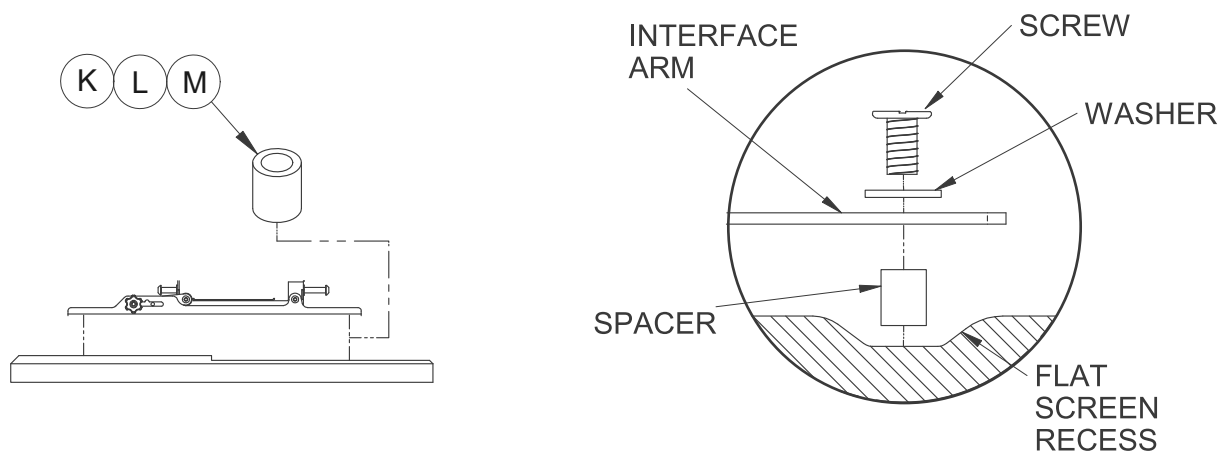

BT8390-VESA200T / BT8390-VESA400T

For tilt adjustment, use the 4AF hex key (part G6) to loosen the screw and thumbwheel on the interface arms. Re-tighten screw to fix tilt angle before mounting screen.

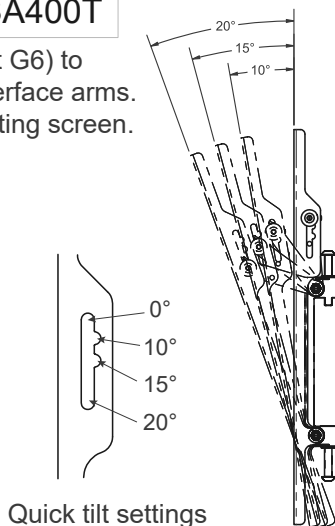
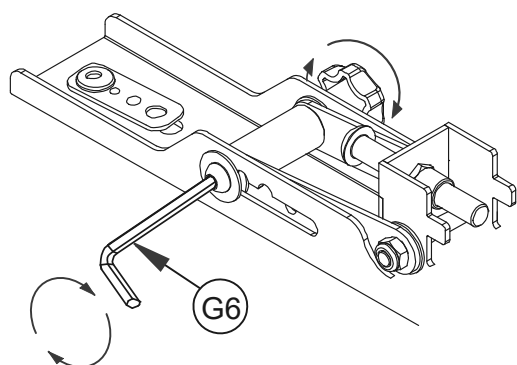

Note: Fix tilt angle on interface arm before mounting screen to rail.

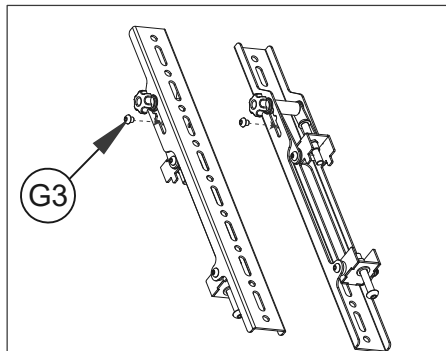

Two M6 x 6mm (part G3) screws are required for a flat 0° display.

5B

Attaching Micro-Adjustment Interface Arms to Screen (BT8390-VESA400MAF)

Attach the interface arms (items G1) to the back of the screen using the screen fixing kit (items D-I). Ensure the arms are positioned the correct way round and the same holes are used on both arms.

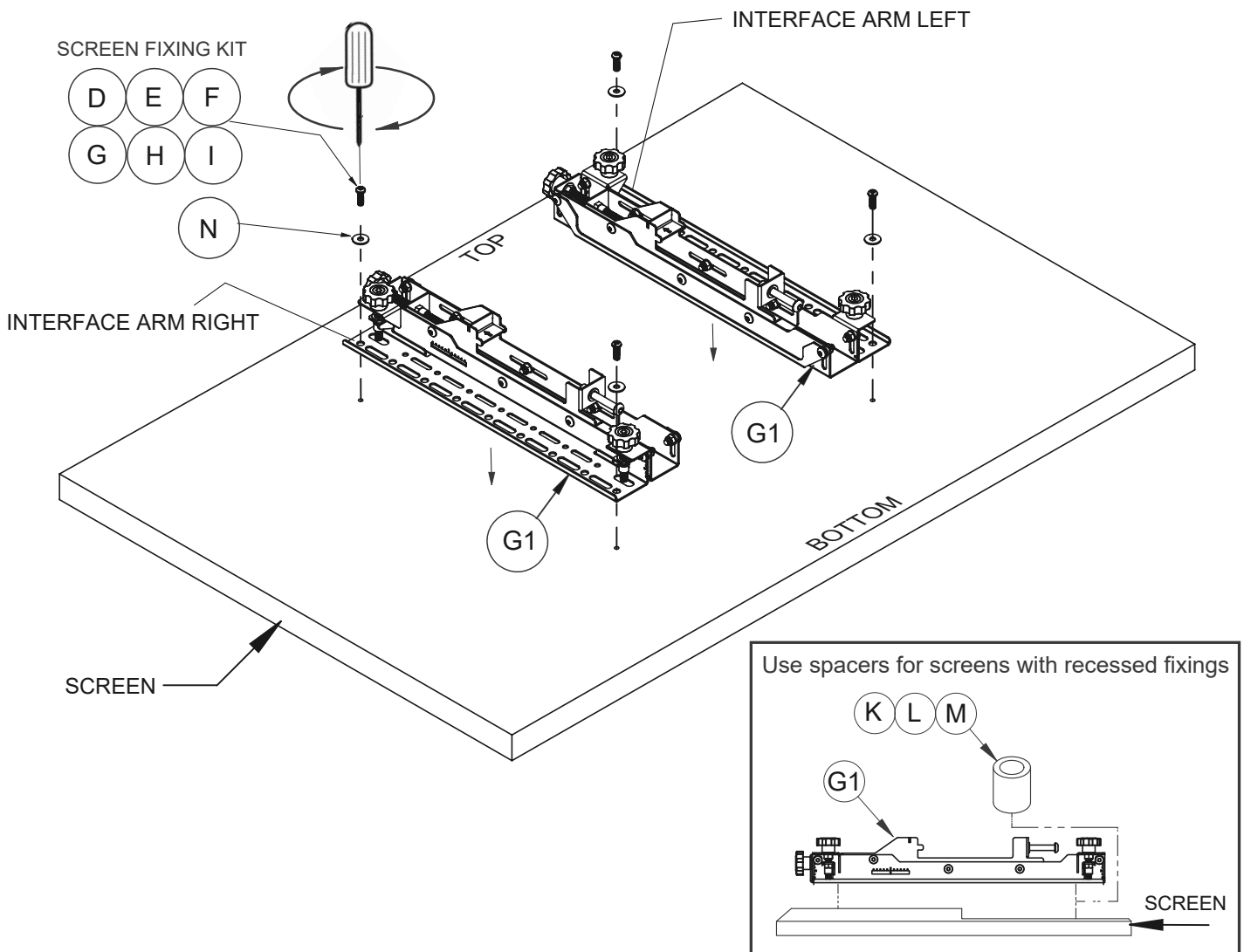

Using Interface Adaptor Arms

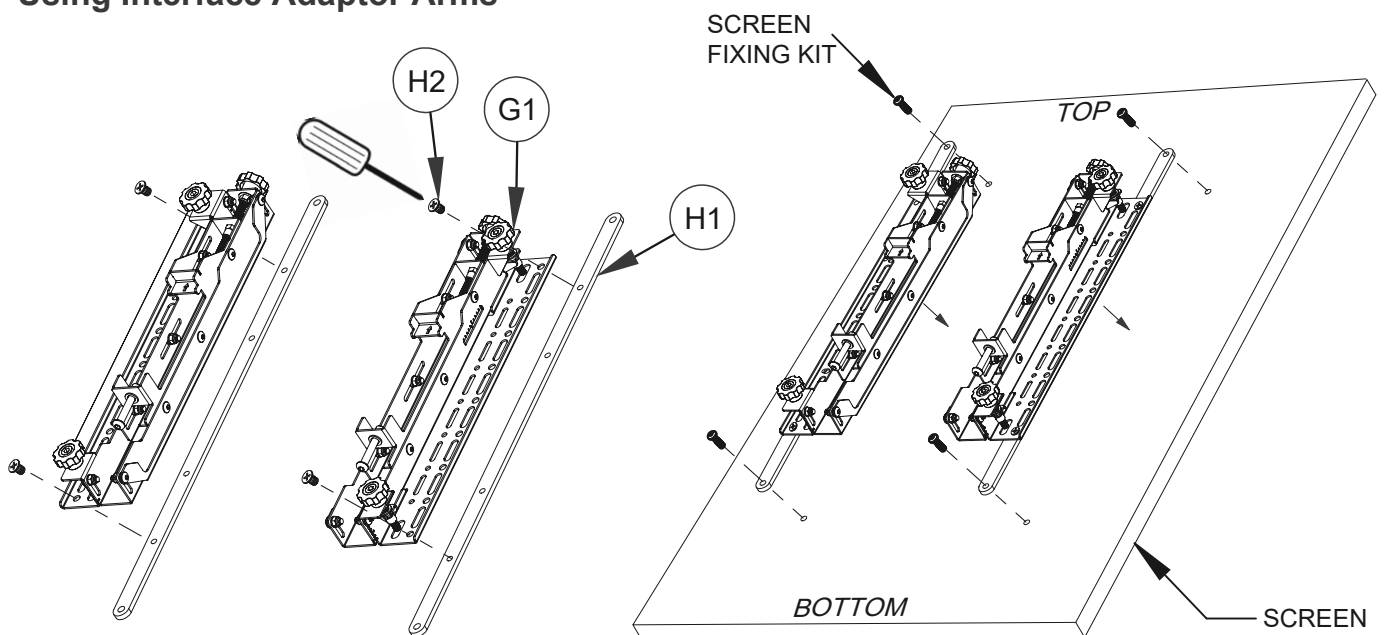

NOTE: Portrait mounting shown.
For landscape mounting attach adaptor arms horizontally

Attaching Pop-Out Interface Arms to Screens (BT8390-VESA400MAP)

- i. Attach the interface arms (items G1) to the back of the screen using the screen fixing kit (items D-I). Ensure the arms are positioned the correct way round and the same holes are used on both arms.

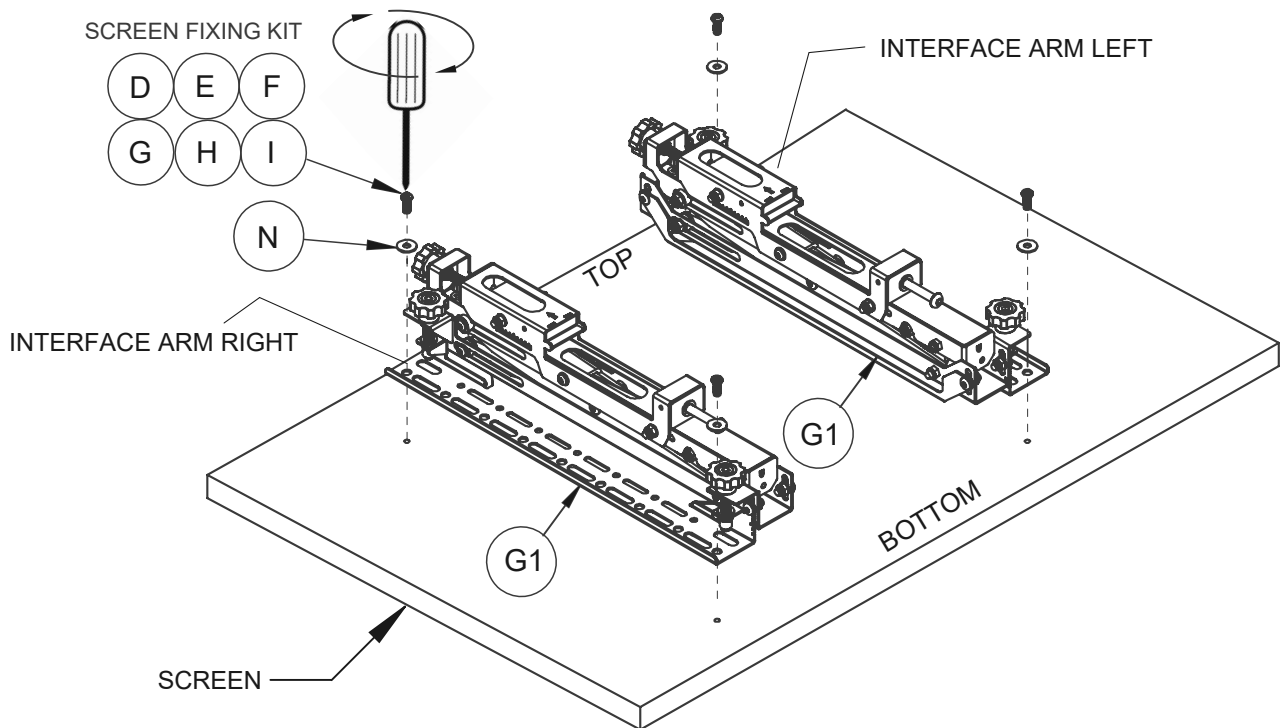

- ii. Connect interface arms with the adjustable brace. Extend brace (item G3) and fix at desired length by tightening the 2 screws. The 3 notches show the position for interface fixings at 400mm, 500mm and 600mm.

Note: The adjustable brace is only suitable for horizontal VESA fixings from 400 - 600mm.

- iii. Fix brace (item G3) inbetween the interface arms (items G1) for easy lateral adjustment of the screen.

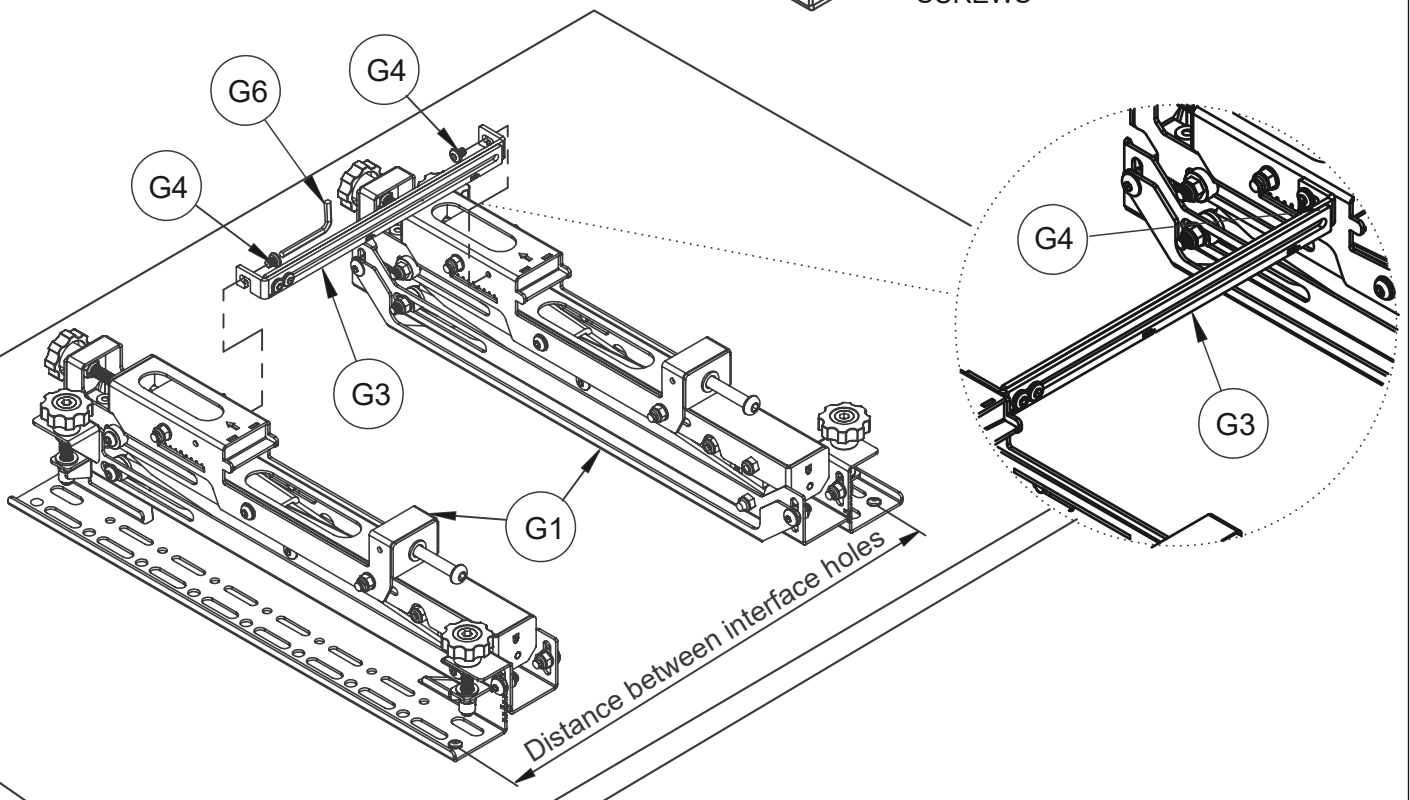
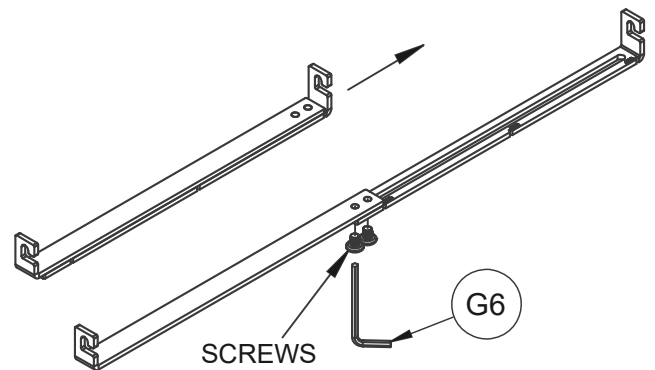

6

Mount Screen to Rail

i. Hook the first screen onto bottom left of the stand.

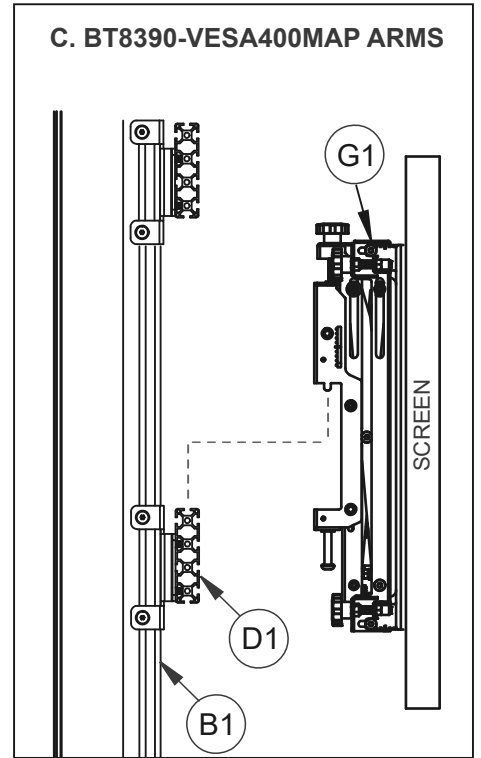
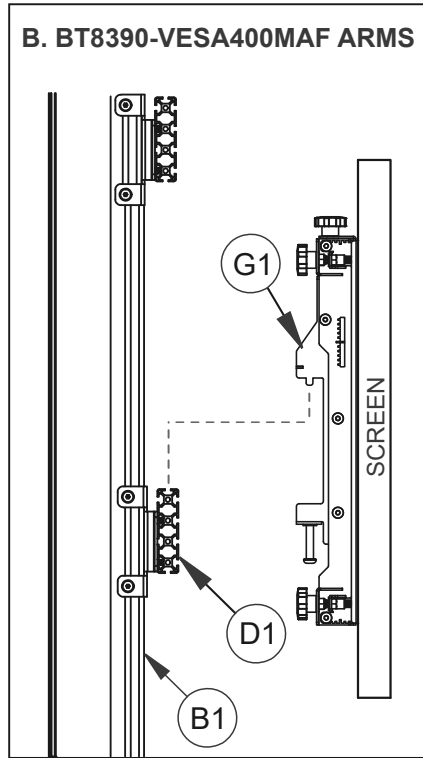
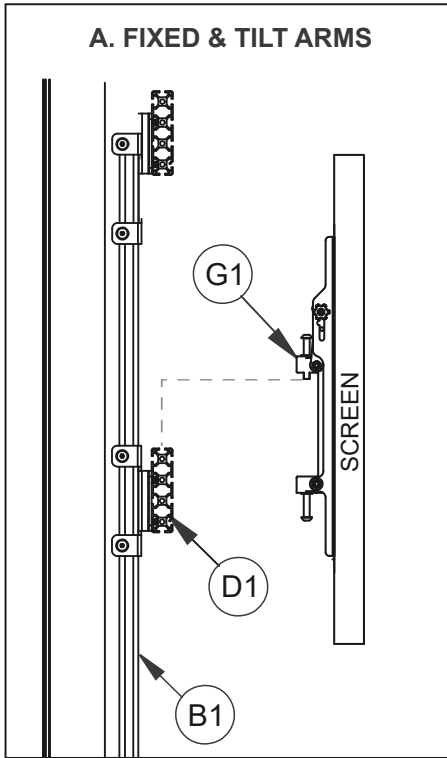

ii. With a level, align the screen to the floor using the height adjustment screws / knobs on top of the interface arms.

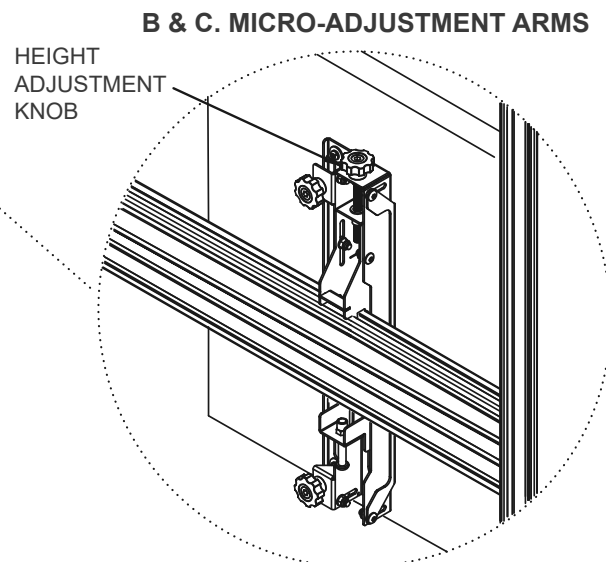
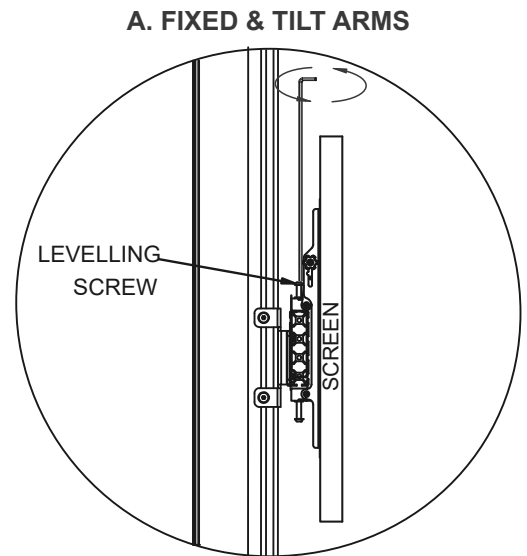
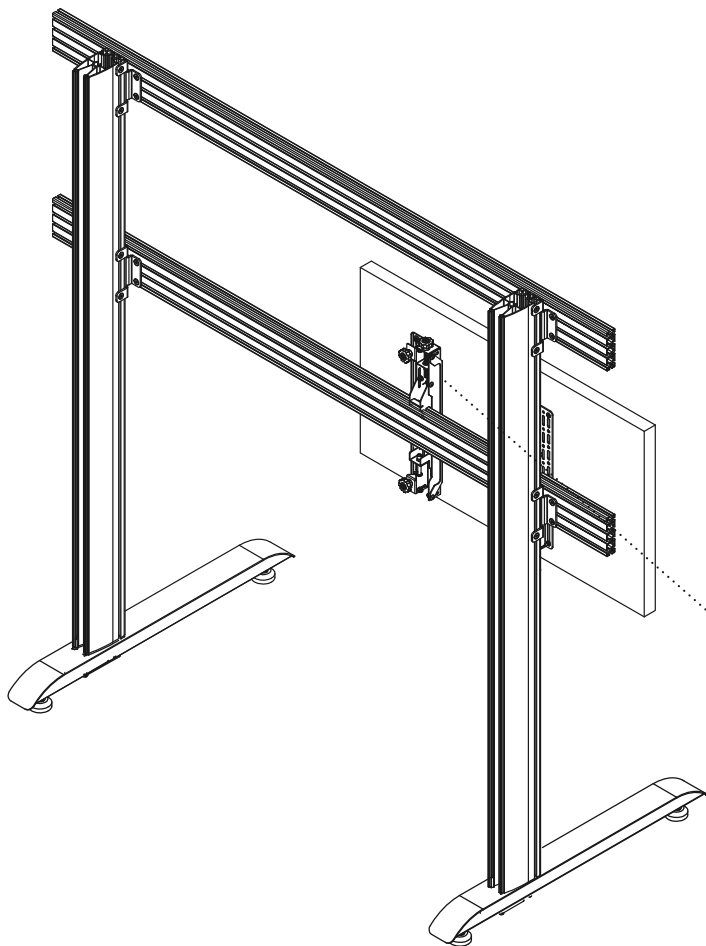

iii. Laterally adjust screen by hand.

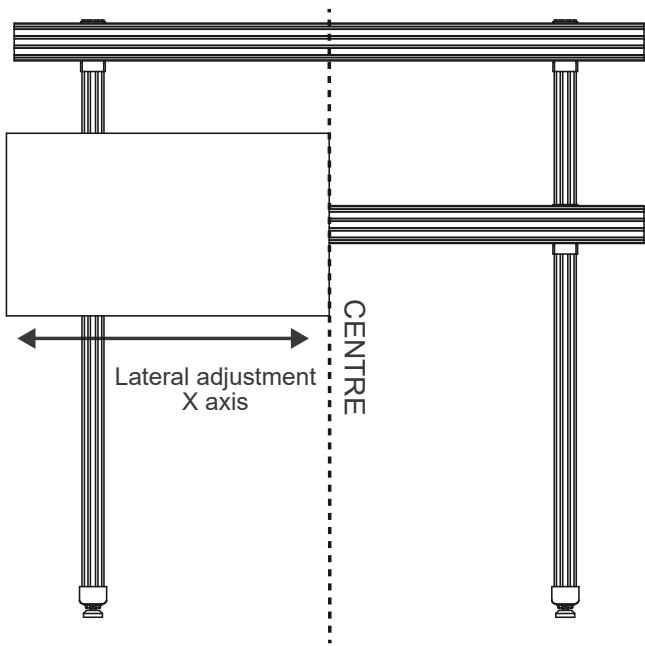

3 x 3 Video wall installation example

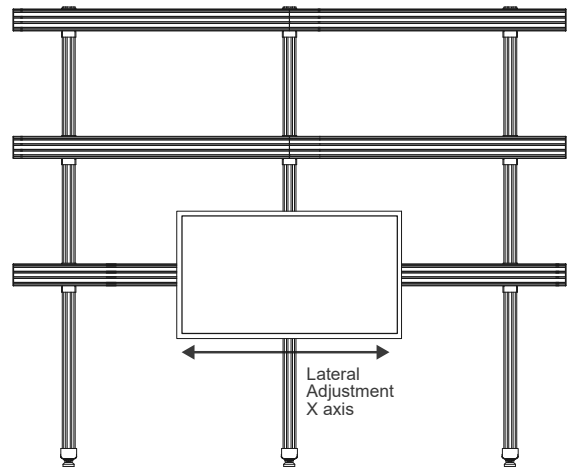

NOTE: If mounting 3 or more screens across, mount the first screen centrally onto the bottom rail.

7

Hook on the remaining screens

After mounting each screen use the Y & Z micro-adjustment knobs on the interface arms to level and align screen* (see next page).

*Only applicable when using the BT8390-VESA400MAF or BT8390-VESA400MAP interface arms

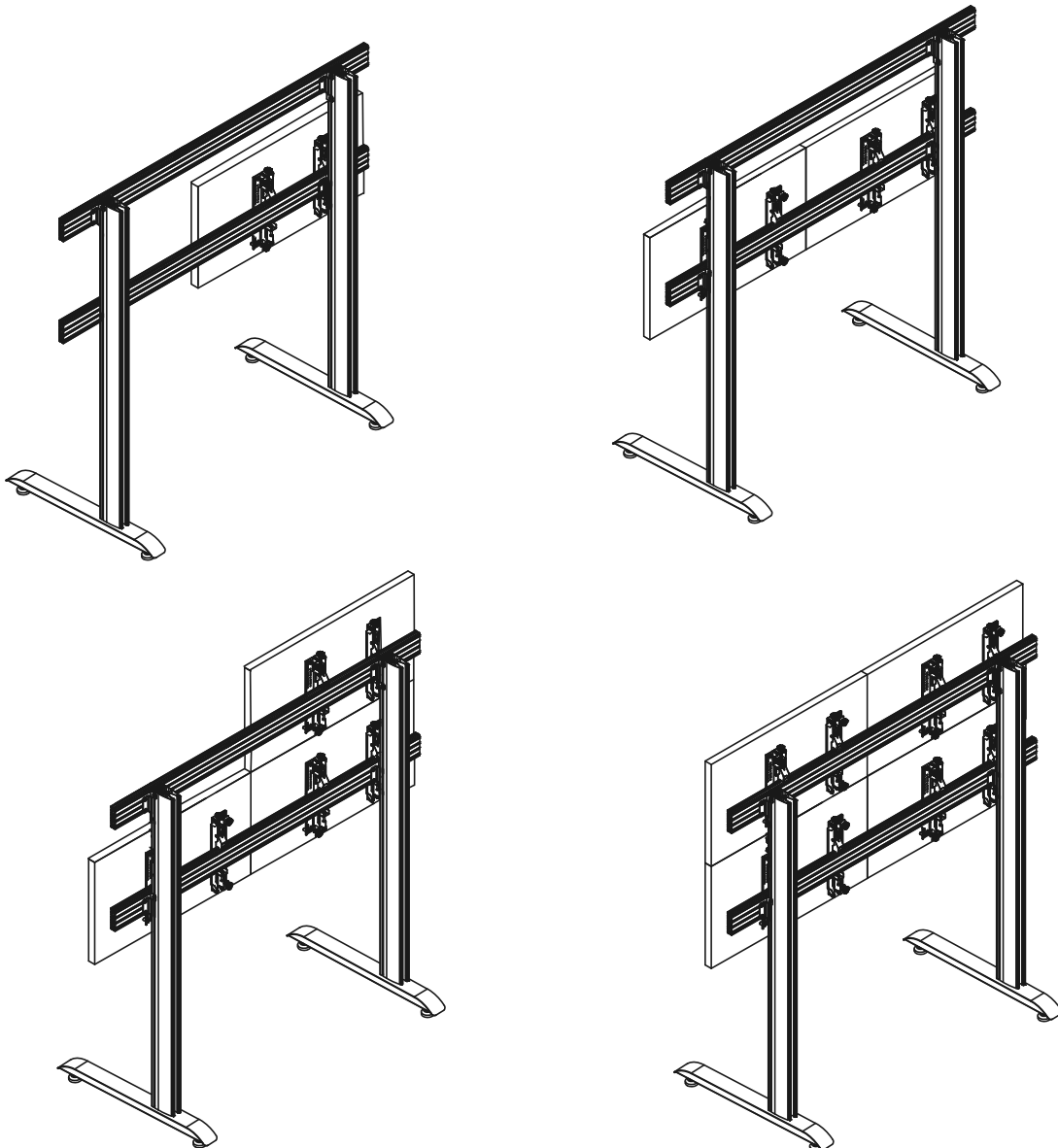

Using a level, align the screen to the floor using the Z axis adjustment knobs.
 Use the Y axis knobs to ensure the screen is perpendicular with the floor.

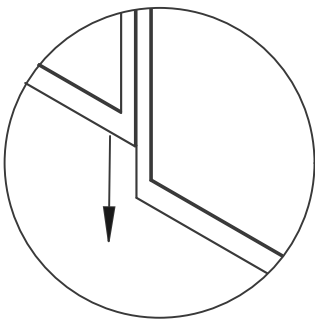
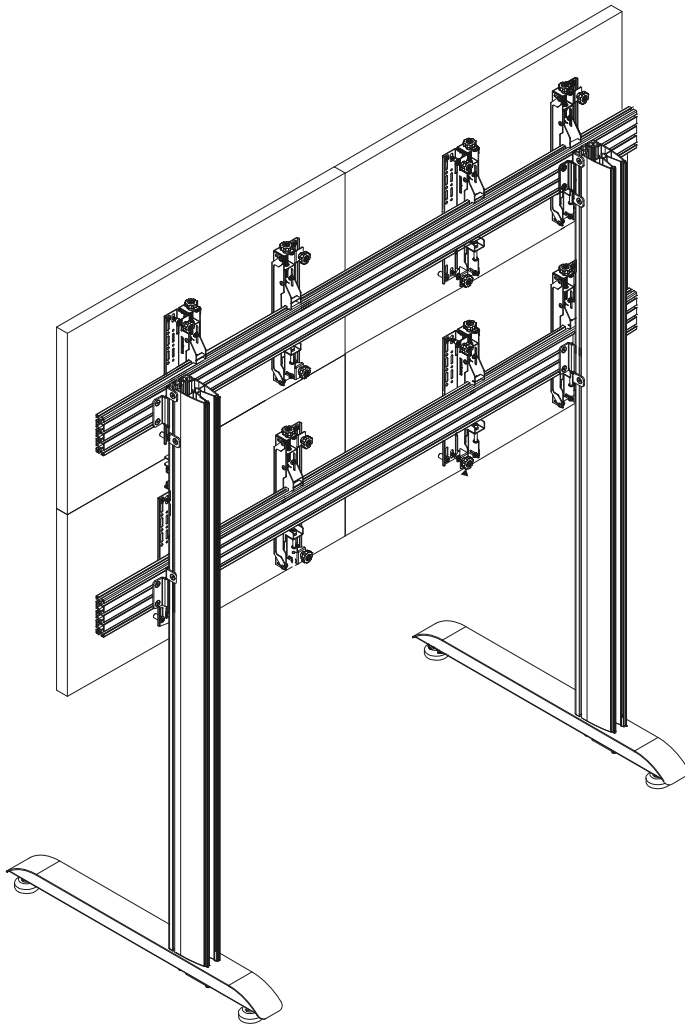

Height Adjustment (Z axis knobs)
to align bottom/top of screens

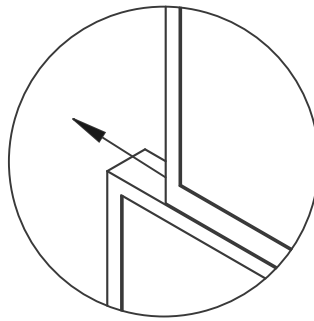

Lateral Adjustment
to align sides of screens

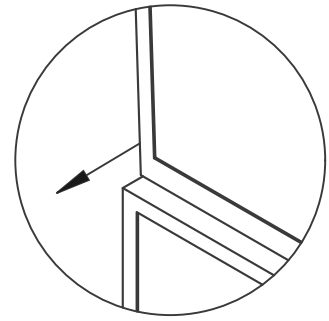

Depth Adjustment (Y axis knobs)
to align front of screens

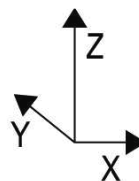
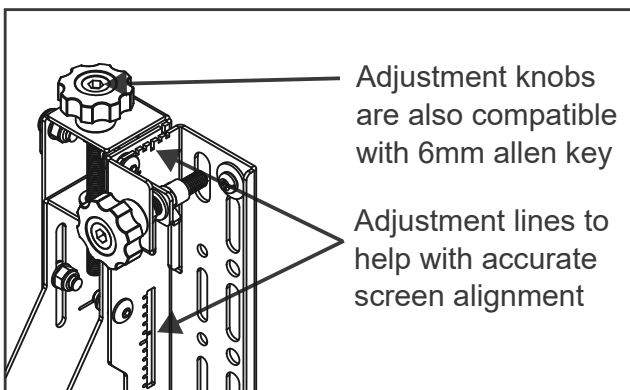

Note: Light pressure in the desired direction of travel will assist in the adjustment of knobs when using heavier screens

BT8390-VESA400MAF
 Total Y axis adjustment is 20mm
 Total Z axis adjustment is +/-25mm

BT8390-VESA400MAP
 Total Y axis adjustment is 20mm
 Total Z axis adjustment is +/-20mm

8

Secure Screens

Once screens are aligned, tighten the safety screws on the bottom of interface arms (item G1).

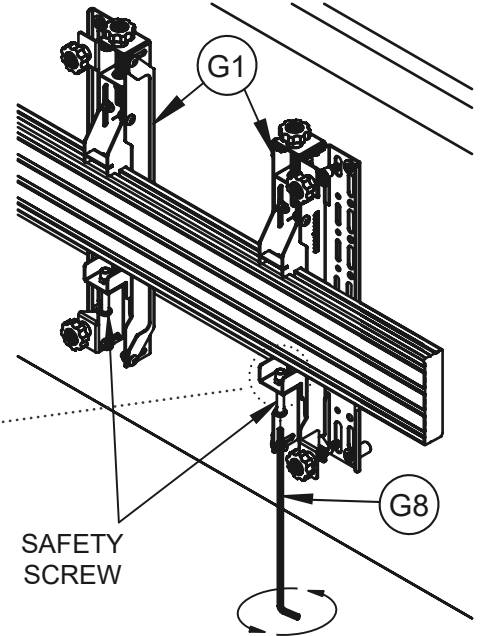
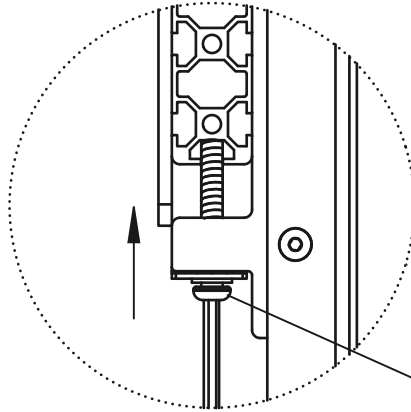
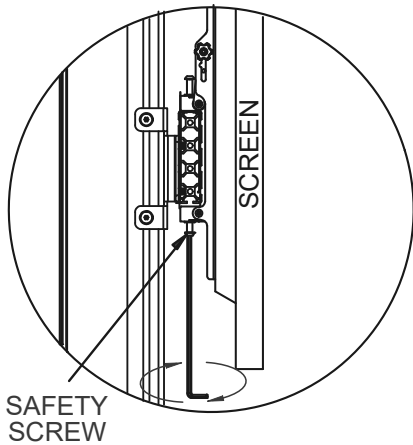

9

Servicing Screens (Pop-Out Arms only)

Push centrally at the left and right of the screen to pop-out the mount. The screen will rest in the 'open' position for servicing.

Note: Ensure pop-out function is not disabled (see below).

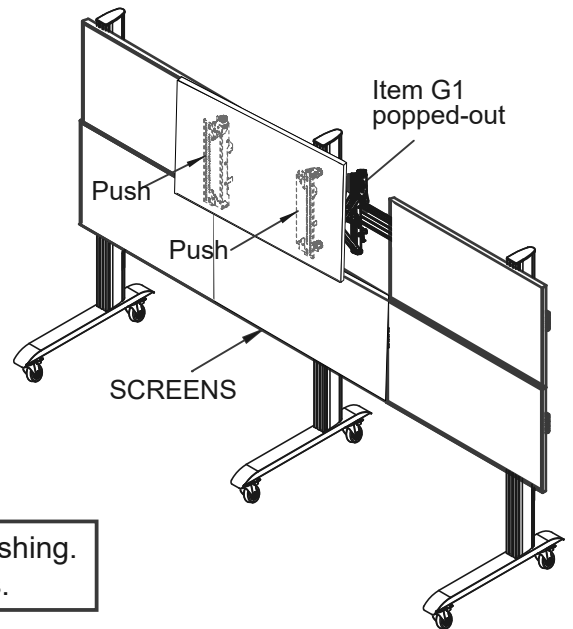

IMPORTANT: Be careful not to damage the screen when pushing. Keep hold of the screen as it moves outwards.

Disabling Pop-Out Function (optional)

To prevent interface arms from popping out, fully insert and tighten the M6 x 35mm screw (item G5) at the padlock* symbol at the bottom of interface arms (items G1).

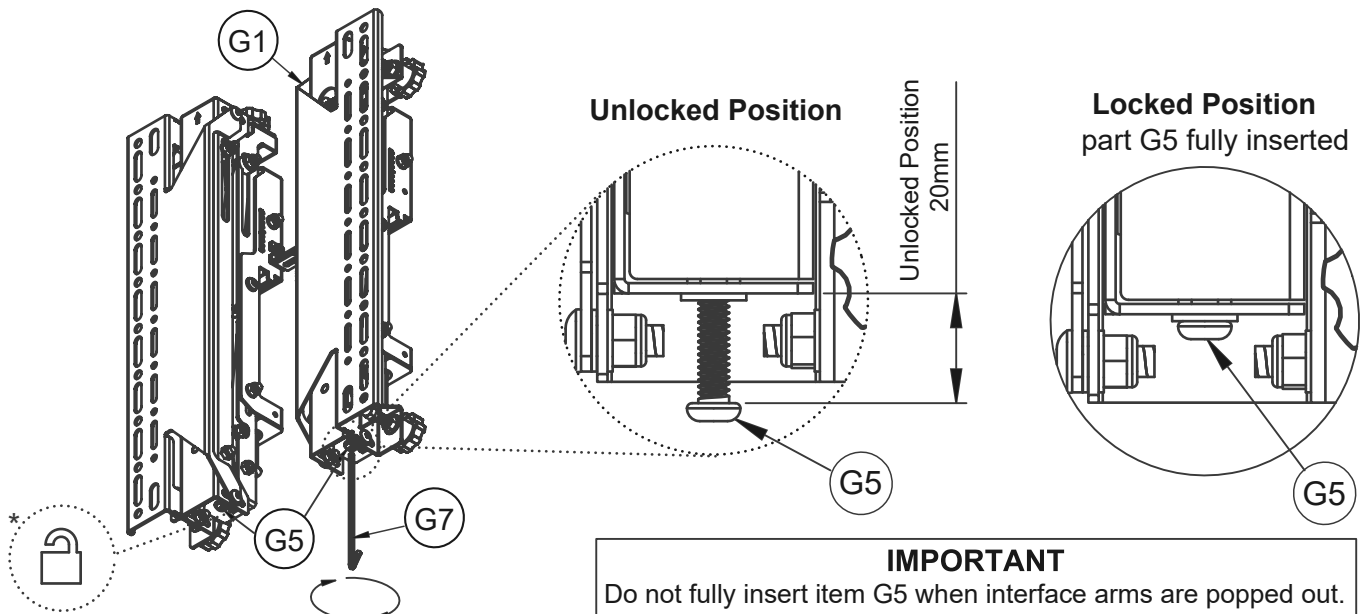

IMPORTANT
Do not fully insert item G5 when interface arms are popped out.

Add End Caps and Cable Management Covers

- i. After screen cables are connected and routed down the back of the columns (item B1), partially clip on the cable management covers (item B3), this allows easy removal if more cables need adding. Once satisfied all cables are fitted, clip the covers on fully.
- ii. Fit end caps (items B2 & D2) to the columns and mounting rails (item B1 & D1).
- iii. With a knife, cut to length the plastic slot inserts (item B4) and insert to the front and sides of the columns (item B1).

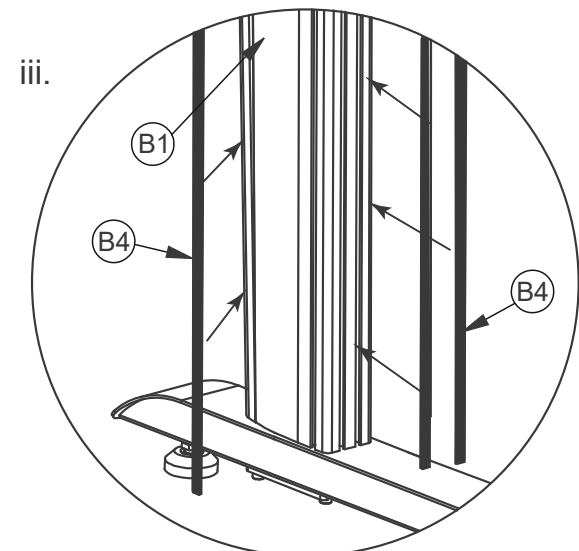
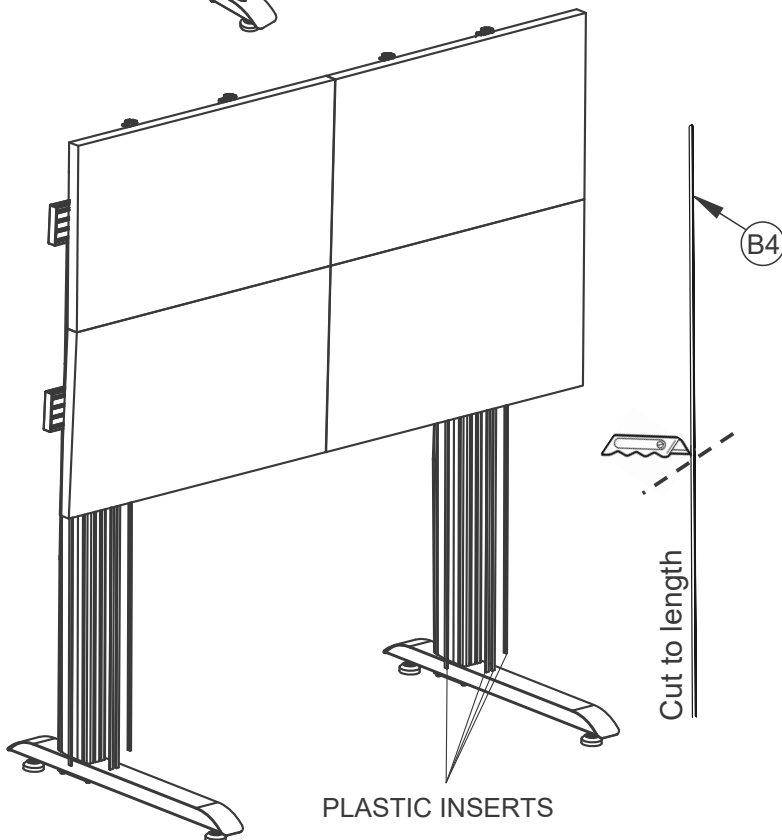
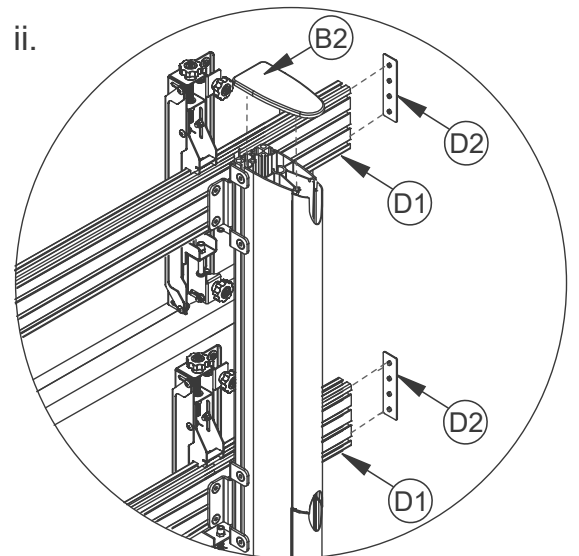
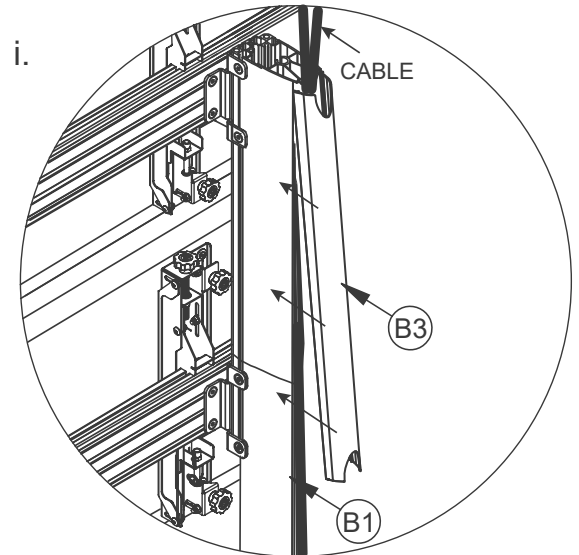
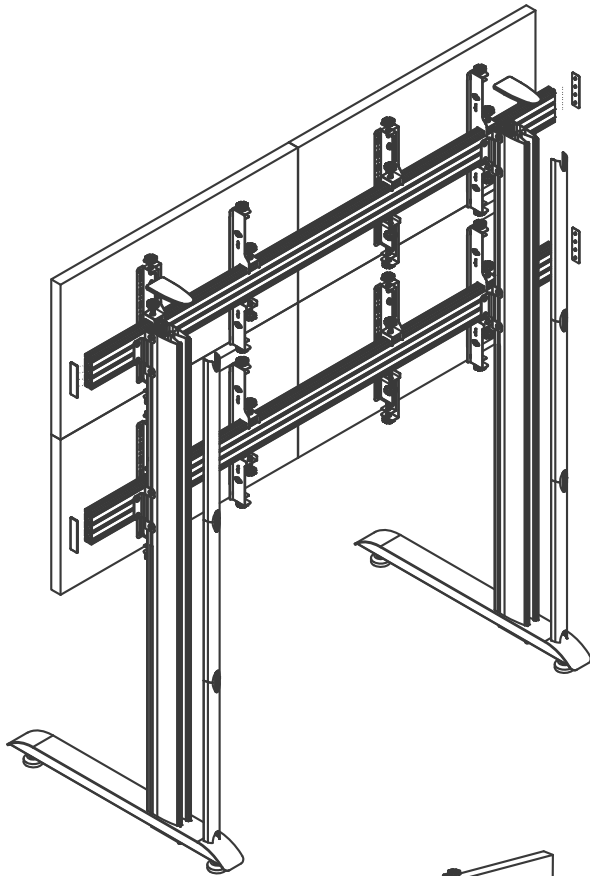

OPTIONAL ACCESSORIES

Wall Tie-Back

BT8380-WTB

For larger installations attach a *BT8380-WTB* Wall tie-back to a vertical column (item B1) and secure to a wall.

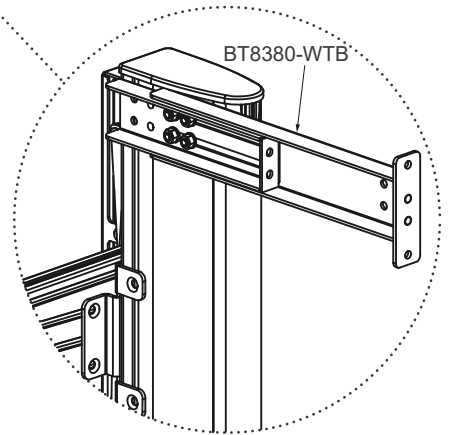
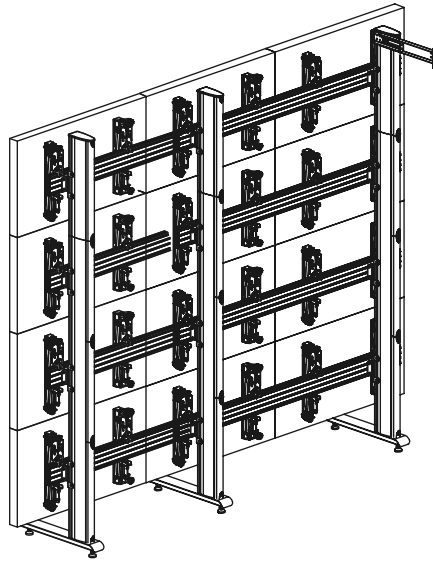

Castors

BT8380-CASTORS

For a mobile application add *BT8380-CASTORS* to the base (item A1). *Supplied in pairs.*
Note: Suitable for use with the *BT8380-BASE* only.

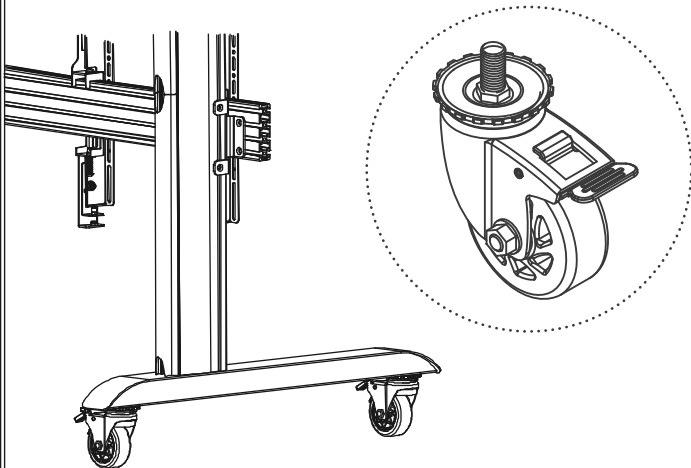

Floor Fixing Kit

BT8380-FBFK

Using suitable fixings and floor anchors, attach a floor base fixing bracket to the front and back of each base (item A1).

Note: The Floor Fixing Kit can only be used when the levelling feet are attached to the base.

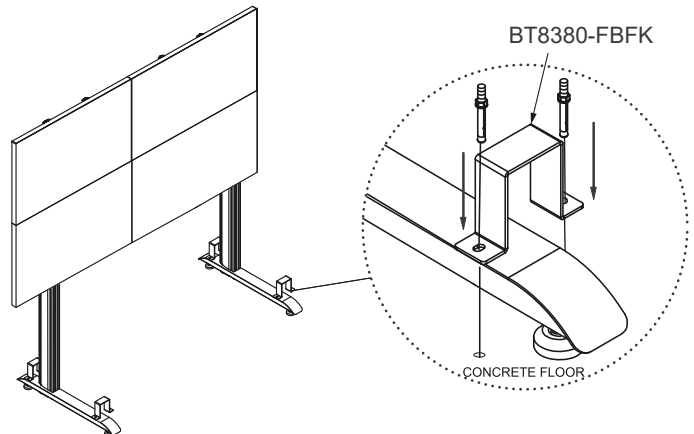

Cable Management Clip

BT8390-CMC

Attach the *BT8390-CMC* cable management clips directly to the mounting rail (item D1) to organise screen cables for a neat and tidy installation.

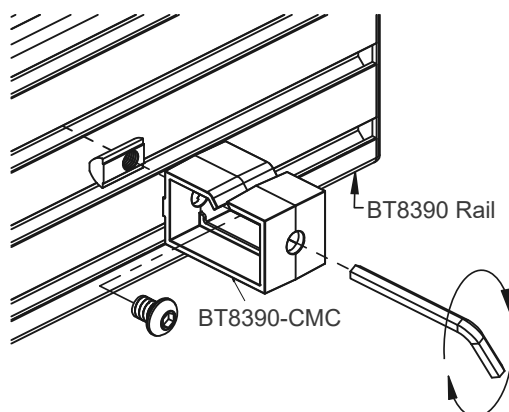

AV Component Shelves

Mount a B-Tech shelf to a vertical column (item B1) using the M8 x 12mm screws (item B6) and M8 sliding nuts (item B5).

Use a *BT8390-SA* shelf adaptor to mount shelves to the horizontal mounting rail (item D1).

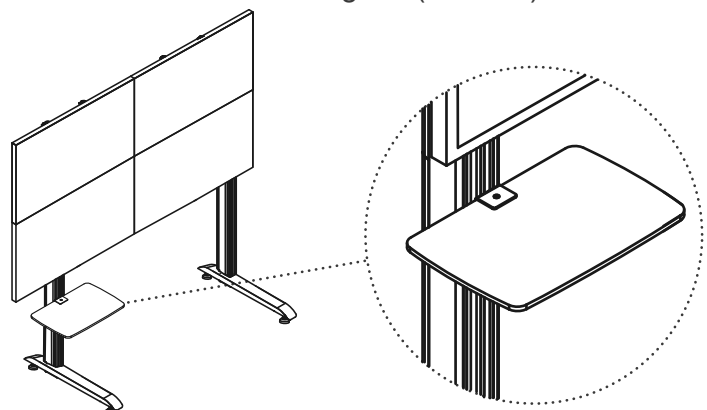



www.btechavmounts.com

B-TECH AV MOUNTS

HEAD OFFICE

B-Tech International Limited

Bennett House, Long March, Daventry, Northants., NN11 4NR, UK

Email: info@btechavmounts.com

©2019 B-Tech International Design and Manufacturing Limited. All rights reserved.

B-Tech AV Mounts is a division of B-Tech International Design & Manufacturing Ltd.

B-Tech, Better By Design & System X are registered trademarks of B-Tech International Design & Manufacturing Ltd.

All other brands and product names are trademarks of their respective owners.

Photographs are for illustrative purposes only. E&OE.